

**Toshiba Personal Computer**

**Satellite L950/L955/S950/S955**

**(PSKGG/PSKGL)**

**Maintenance Manual**

**TOSHIBA CORPORATION**

S/ No

## **Copyright**

© 2012 by Toshiba Corporation. All rights reserved. Under the copyright laws, this manual cannot be reproduced in any form without the prior written permission of Toshiba. No patent liability is assumed with respect to the use of the information contained herein.

Toshiba Satellite L950/L955/S950/S955 Maintenance Manual

First edition September of 2012

## **Disclaimer**

The information presented in this manual has been reviewed and validated for accuracy. The included set of instructions and descriptions are accurate for the Satellite L950/L955/S950/S955 at the time of this manual's production. However, succeeding computers and manuals are subject to change without notice. Therefore, Toshiba assumes no liability for damages incurred directly or indirectly from errors, omissions, or discrepancies between any succeeding product and this manual.

## **Trademarks**

Intel and Pentium are registered trademarks of Intel Corporation.

IBM, IBM PC/XT, PC/AT, PS/2 and OS/2 are registered trademarks of IBM Corporation.

Windows 7/8 home edition are registered trademarks of Microsoft Corporation.

Sound Blaster and Pro are trademarks of Creative Technology Ltd.

UNIX is a registered trademark of X/Open Company Ltd.

NetWare are registered trademarks of Novell, Inc.

All other properties are trademarks or registered trademarks of their respective holders.

---

## Preface

---

This maintenance manual describes how to perform hardware service maintenance for the Toshiba Personal Computer Satellite L950/L955/S950/S955, referred to as Satellite L950/L955/S950/S955 in this manual.

The procedures described in this manual are intended to help service technicians isolate faulty Field Replaceable Units (FRUs) and replace them in the field.

### SAFETY PRECAUTIONS

Four types of messages are used in this manual to bring important information to your attention. Each of these messages will be italicized and identified as shown below.

***DANGER:*** “Danger” indicates the existence of a hazard that could result in death or serious bodily injury, if the safety instruction is not observed.

***WARNING:*** “Warning” indicates the existence of a hazard that could result in bodily injury, if the safety instruction is not observed.

***CAUTION:*** “Caution” indicates the existence of a hazard that could result in property damage, if the safety instruction is not observed.

***NOTE:*** “Note” contains general information that relates to your safe maintenance service.

Improper repair of the computer may result in safety hazards. Toshiba requires service technicians and authorized dealers or service providers to ensure the following safety precautions are adhered to strictly.

- ❑ Be sure to fasten screws securely with the right screwdriver. If a screw is not fully fastened, it could come loose, creating a danger of a short circuit, which could cause overheating, smoke or fire.
- ❑ If you replace the battery pack, RTC battery or backup battery, be sure to use only the same model battery or an equivalent battery recommended by Toshiba. Installation of the wrong battery can cause the battery to explode.

The manual is divided into the following parts:

- Chapter 1      Hardware Overview describes the Satellite L950/L955/S950/S955 system unit and each FRU.
- Chapter 2      Troubleshooting Procedures explains how to diagnose and resolve FRU problems.
- Chapter 3      Test and Diagnostics describes how to perform test and diagnostic operations for maintenance service.
- Chapter 4      Replacement Procedures describes the removal and replacement of the FRUs.
- Appendices    The appendices describe the following:
  - Handling the LCD module
  - Board layout
  - Keyboard scan/character codes
  - Key layout



## Conventions

This manual uses the following formats to describe, identify, and highlight terms and operating procedures.

### *Acronyms*

On the first appearance and whenever necessary for clarification acronyms are enclosed in parentheses following their definition. For example:

Read Only Memory (ROM)

### *Keys*

Keys are used in the text to describe many operations. The key top symbol as it appears on the keyboard is printed in **boldface** type.

### *Key operation*

Some operations require you to simultaneously use two or more keys. We identify such operations by the key top symbols separated by a plus (+) sign. For example, **Ctrl + Pause (Break)** means you must hold down **Ctrl** and at the same time press **Pause (Break)**. If three keys are used, hold down the first two and at the same time press the third.

### *User input*

Text that you are instructed to type in is shown in the boldface type below:

**DISKCOPY A: B:**

### *The display*

Text generated by the XXXXX that appears on its display is presented in the type face below:

```
Format complete  
System transferred
```

---

# Table of Contents

---

## Chapter 1 Hardware Overview

1.1 Features .....	4
1.2 System Unit Components .....	10
1.3 2.5-inch HDD .....	15
1.4 DVD Super Multi (+-R Double Layer) .....	16
1.5 Blu-Ray Writer .....	17
1.6 Blu-Ray COMBO .....	18
1.7 Power Supply .....	19
1.8 Batteries .....	20
1.81 Main Battery .....	20
1.82 Battery Charging Control .....	20
1.83 One time RTC Battery .....	21

## Chapter 2 Troubleshooting

2.1 Outline .....	2-1
2.2 Basic Flowchart .....	2-2
2.3 Power Supply .....	2-6
Procedure 1 Power Icon Check .....	2-6
Procedure 2 Connection Check .....	2-8
Procedure 3 Replacement Check .....	2-8
2.4 System Board .....	2-9
Procedure 1 Message Check .....	2-9
Procedure 2 Test Program Check .....	2-10
Procedure 3 Replacement Check .....	2-10
2.5 HDD .....	2-11
Procedure 1 Message Check .....	2-11
Procedure 2 Partition Check .....	2-11
Procedure 3 Format Check .....	2-12
Procedure 4 Test Program Check .....	2-13

	Procedure 5 Connector Check and Replacement Check.....	2-14
2.6	Keyboard .....	2-15
	Procedure 1 Test Program Check.....	2-15
	Procedure 2 Connector Check and Replacement Check.....	2-15
2.7	Display.....	2-16
	Procedure 1 External Monitor Check.....	2-16
	Procedure 2 Test Program Check.....	2-16
	Procedure 3 Connector Check and Replacement Check.....	2-16
2.8	ODD (Optical Disk Drive) .....	2-18
	Procedure 1 ODD Cleaning Check .....	2-18
	Procedure 2 Test Program Check.....	2-18
	Procedure 3 Connector Check and Replacement Check.....	2-18
2.9	LAN.....	2-20
	Procedure 1 Test Program Check.....	2-20
	Procedure 2 Connector Check and Replacement Check.....	2-20
2.10	Audio Test.....	2-21
	Procedure 1 Test Program Check.....	2-21
	Procedure 2 Connector Check and Replacement Check.....	2-21
2.11	Cooling Module.....	2-22
	Procedure 1 Test Program Check.....	2-22
	Procedure 2 Connector Check and Replacement Check.....	2-22
2.12	Touchpad.....	2-23
	Procedure 1 Test Program Check.....	2-23
	Procedure 2 Connector Check and Replacement Check.....	2-23
2.13	Memory .....	2-24
	Procedure 1 Test Program Check.....	2-24
	Procedure 2 Connector Check and Replacement Check.....	2-24
2.14	USB Port.....	2-25
	Procedure 1 Windows Application Test .....	2-25
	Procedure 2 Connector Check and Replacement Check.....	2-25
2.15	Headphone Port .....	2-26
	Procedure 1 Windows Application Test .....	2-26
	Procedure 2 Connector Check and Replacement Check.....	2-26

2.16	Microphone Port.....	2-27
	Procedure 1 Windows Application Test .....	2-27
	Procedure 2 Connector Check and Replacement Check.....	2-27
2.17	Video RGB Port .....	2-28
	Procedure 1 Windows Application Test .....	2-28
	Procedure 2 Connector Check and Replacement Check.....	2-28
2.18	Card Reader.....	2-29
	Procedure 1 Windows Application Test .....	2-29
	Procedure 2 Connector Check and Replacement Check.....	2-29
2.19	Camera.....	2-30
	Procedure 1 Windows Application Test .....	2-30
	Procedure 2 Connector Check and Replacement Check.....	2-30
2.20	Wireless LAN.....	2-31
	Procedure 1 Windows Application Test .....	2-31
	Procedure 2 Connector Check and Replacement Check.....	2-31
2.21	Battery Pack.....	2-32
	Procedure 1 Windows Application Test .....	2-32
	Procedure 2 Connector Check and Replacement Check.....	2-32
2.22	HDMI Port.....	2-33
	Procedure 1 Windows Application Test .....	2-33
	Procedure 2 Connector Check and Replacement Check.....	2-33

### **Chapter 3      Diagnostic Programs**

3.1	General .....	1
3.2	Quick Start.....	3
	3.2.1 Quick Test .....	3
	3.2.2 Customization Test.....	3
	3.2.3 Keyboard Layout test.....	7
	3.2.4 Audio Play Test.....	8
	3.2.5 Audio Record Test.....	9

3.2.6	DMI Read .....	9
3.2.7	DMI Write .....	10
3.2.8	System Information .....	11
3.2.9	View Logs .....	13
3.2.10	Exit to Free DOS .....	13
3.2.11	The Diagnostics Screen Explanation.....	13
3.3	Options .....	17
3.3.1	Overview .....	17
3.3.2	Batch Parameters Configuration.....	18
3.3.3	Item's Parameters Configuration.....	20
3.3.4	Load Batch Parameters .....	21
3.3.5	Save Batch Parameters .....	22
3.3.6	LOG Parameters Setting.....	23
3.3.7	Specify LOG Viewer .....	24
3.3.8	Display LOG File .....	24
3.3.9	LOG Viewer .....	25
3.3.10	LOG File Sample.....	26
3.4	Subtests.....	28
3.5	System Test .....	31
3.6	Memory Test .....	36
3.7	Storage.....	41
3.8	Video .....	45
3.9	Communication (COMM).....	54
3.10	Peripheral.....	55
3.11	Error Codes and description .....	58
3.12	Quick Test Item List.....	i

## **Chapter 4 Replacement Procedures**

4.1	General .....	4-1
	Safety Precautions .....	4-2
	Before You Begin.....	4-4
	Disassembly Procedures .....	4-5
	Assembly Procedures .....	4-5

	Tools and Equipment .....	4-6
	Screw Tightening Torque .....	4-6
	Colors of Screw Shanks .....	4-7
	Symbols of Screws on the Computer Body .....	4-7
	Symbol examples .....	4-7
4.2	Battery Pack/Bridge Media .....	4-8
	4.2.1 Battery Pack .....	4-8
	Removing the Battery Pack .....	4-8
	Installing the Battery Pack .....	4-9
	4.2.2 Bridge Media .....	4-10
	Removing the Bridge Media .....	4-10
	Installing the Bridge Media .....	4-10
4.3	Memory Module and RTC Battery .....	4-11
	Remove the Memory Module and RTC Battery .....	4-11
	Installing the Memory Module and RTC Battery .....	4-12
4.4	HDD .....	4-13
	Removing the HDD .....	4-13
	Installing the HDD .....	4-14
4.5	ODD Bay Module .....	4-15
	Removing the ODD Bay Module .....	4-15
	Installing the ODD Bay Module .....	4-16
	Disassembling the ODD Drive .....	4-17
	Assembling the ODD Drive .....	4-17
4.6	Keyboard .....	4-18
	Removing Keyboard .....	4-18
	Installing the Keyboard .....	4-20
4.7	Wireless LAN Card .....	4-21
	Removing the Wireless LAN Card .....	4-21
	Installing the Wireless LAN Card .....	4-24
4.8	CPU Cooling Module and Fan .....	4-25
	Removing the CPU Cooling module and Fan .....	4-25
	Installing the CPU Cooling Module and Fan .....	4-27
4.9	System Board .....	4-28

	Removing the System Board.....	4-28
	Installing the System Board.....	4-30
4.10	LCD Module Assembly.....	4-31
	Removing the LCD Module Assembly.....	4-31
	Installing the LCD Module Assembly.....	4-32
4.11	LCD Module Mask.....	4-33
	Remove the Display Mask.....	4-33
	Installing the Display Mask.....	4-34
4.12	LED Panel.....	4-35
	Removing the LED Panel.....	4-35
	Installing the LED Panel.....	4-37
4.13	CCD Module.....	4-38
	Removing the CCD Module.....	4-38
	Installing the CCD Module.....	4-39
4.14	Speakers.....	4-40
	Removing the Speaker.....	4-40
	Installing the Speaker.....	4-40
4.15	Power Board, USB Board and DC-IN harness.....	4-41
	Removing the Power Board, , USB Board and DC-IN Harness.....	4-41
	Installing the Power Board, USB Board and DC-IN Harness.....	4-41
4.16	Touchpad Board.....	4-42
	Removing the Touchpad Board.....	4-42
	Installing the Touchpad board.....	4-42

## Appendices

Appendix A	Handling the LCD Module .....	A-1
Appendix B	Board Layout.....	B-1
Appendix C	Keyboard Scan/Character Codes.....	C-1
Appendix D	Key Layout.....	D-1



---

# Chapter 1

## Hardware Overview

---

---

## **Chapter 1      Contents**

---

1.1 Features.....	4
1.2 System Unit Components.....	10
1.3 2.5-inch HDD.....	15
1.4 DVD Super Multi (+-R Double Layer).....	16
1.5 Blu-Ray Writer.....	17
1.6 Blu-Ray COMBO.....	18
1.7 Power Supply.....	19
1.8 Batteries.....	20
1.81      Main Battery.....	20
1.82      Battery Charging Control.....	20
1.83      One time RTC Battery.....	21

### **Figures**

Figure 1-1 ID Parts Description Placement.....	7
Figure 1-2 Computer Block Diagram.....	8
Figure 1-3 System Board Configurations.....	9
Figure 1-4 System Unit Block Diagram.....	10
Figure 1-5 SATA HDD.....	15
Figure 1-6 DVD Super Multi Drive.....	16
Figure 1-7 Blu-Ray Writer Drive.....	17
Figure 1-8 Blu-Ray Combo Drive.....	18

### **Tables**

Table 1-1 HDD Specifications.....	15
Table 1-2 DVD Super Multi Drive Specifications.....	16
Table 1-3 Blu-Ray Writer Drive Specifications.....	17

Table 1-4 Blu-Ray Combo Drive Specifications..... 18  
Table 1-5 Battery Specifications ..... 20  
Table 1-6 Quick/Normal Charging Time ..... 21

### 1.1 Features

Toshiba Satellite L950/L955/S950/S955 is a full size notebook PC based on the mobile Intel Sandy and Ivy Bridge Processor, providing high-speed processing capabilities and advanced features. The computer employs a Lithium Ion battery that allows it to be battery-operated for a longer period of time. The display uses 15.6-inch HD CSV LCD panel, at a resolution of 1366x768.

The computer has the following features:

Processor

CPU is mobile Intel Sandy and Ivy Bridge Processor:

Intel Core i5 CPU (1600MHz FSB)

Core i5-3317U 1.70GHz

Intel Core i3 CPU (1600MHz FSB)

Core i3-3217U 1.80GHz

Host Bridge System Controller

System Controller: Intel panther Point Chipset HM70/HM76.

Graphics

Intel integrated graphics.

Memory

The computer has two SO-DIMM slots, which come standard with DDR3-1600MHz (PC3-12800) memory module. DDR3 is driven at 1.5V. It accepts BTO/CTO for your memory requirements. It can incorporate up to 16GB of main memory.

Using the following sizes of memory modules:

- 2048 MB (256M×64) / DDR3-1600MHz
- 4096 MB (512M×64) / DDR3-1600MHz
- 8192 MB (1024M×64) / DDR3-1600MHz

Hard Disk Drive (HDD)

The computer accommodates 2.5-inch 7mm/9.5mm height Serial ATA HDD with following storage capacities:

- 320 GB (7mm/9.5mm thick) SATA (5,400rpm)
- 500 GB (7mm/9.5mm thick) SATA (5,400rpm)
- 640 GB (9.5mm thick) SATA (5,400rpm)
- 750 GB (9.5mm thick) SATA (5,400rpm)
- 1 TB (9.5mm thick) SATA (5,400rpm)

 ODD

The computer accommodates a fixed 9.5mm ODD with one of following types:

- Tray Type DVD Super Multi +-R Double Layer drive
- Tray Type BD Combo drive
- Tray Type BD Writer drive

 Display

LCD displays come in the following type at resolution 1366x768:

- 15.6" HD 1366x768 CSV LED display

 On-Board LAN

The internal LAN supports 10/100Mbit and 10/100/1Gbit Ethernet, enabling connection to a LAN at up to 1Gbps. It supports Wake-up on LAN from S3/S4/S5 and PXE boot support. This internal LAN has RJ45 jack to directly accommodate a LAN cable.

 Wireless LAN

The internal Mini Card slot supports IEEE802.11bgn / IEEE802.11abgn cards, and WLAN + Bluetooth combo card is also supported. The Antenna has one or two wires dual band.

 Sound System

REALTEK ALC269Q integrated audio controller supports multimedia. The sound system contains the following:

- Stereo speakers

- Headphone jack
- Integrated microphone(BTO with Webcam)
- External microphone jack

Keyboard

35 kinds' countries keyboard, which is Toshiba 2012 A4 with numeric keypad keyboard.

Toshiba Touch Pad

Normal Touch Pad (w/ 2 mechanical buttons)

USB Port (BTO)

The computer has three USB ports for USB2.0 and USB3.0 BTO selection. High-Speed USB3.0 allows data transfers up to 5Gbps and USB2.0 allows data transfers up to 480Mbps, and supports Sleep & Charge Function.

RGB External Monitor Port

A 15-pin external monitor port is provided, through which the computer automatically recognizes an external VESA DDC 2B compatible monitor.

HDMI Out Port

A HDMI monitor can be connected to HDMI Out Port on the computer.

Bridge Media Slot

This slot is for your memory card requirements like SD/Mini SD(need Converter)/Micro SD(need Converter)/SDHC/SDXC and MMC Cards to provide memory card read on your computer.

Webcam (BTO)

The computer has an internal camera. It supports HD(1.0M) without Auto Macro and FHD(2M) without Auto Macro module. Camera LED is supported; LED is on when Camera is working. The internal microphone is embedded in this camera module.

Battery

The computer has a removable 4 Cell Lithium Ion battery pack and a onetime RTC battery (non-rechargeable)

□ Figures 1-1/1-2/1-3 and 1-4 show the computer and its system unit configuration, respectively.

**ID Specification**

1:4

Fez		AL		
Ver. 0.5	Date : 2012-06-22	DESIGNER	Howli Hsu	
Issue : For Fez ES Build.		MANAGE	Ajax Chen	
TOSHIBA APPROVE	TOSHIBA CHECK	TDC APPROVE	PROJECT MANAGER	PROJECT LEADER

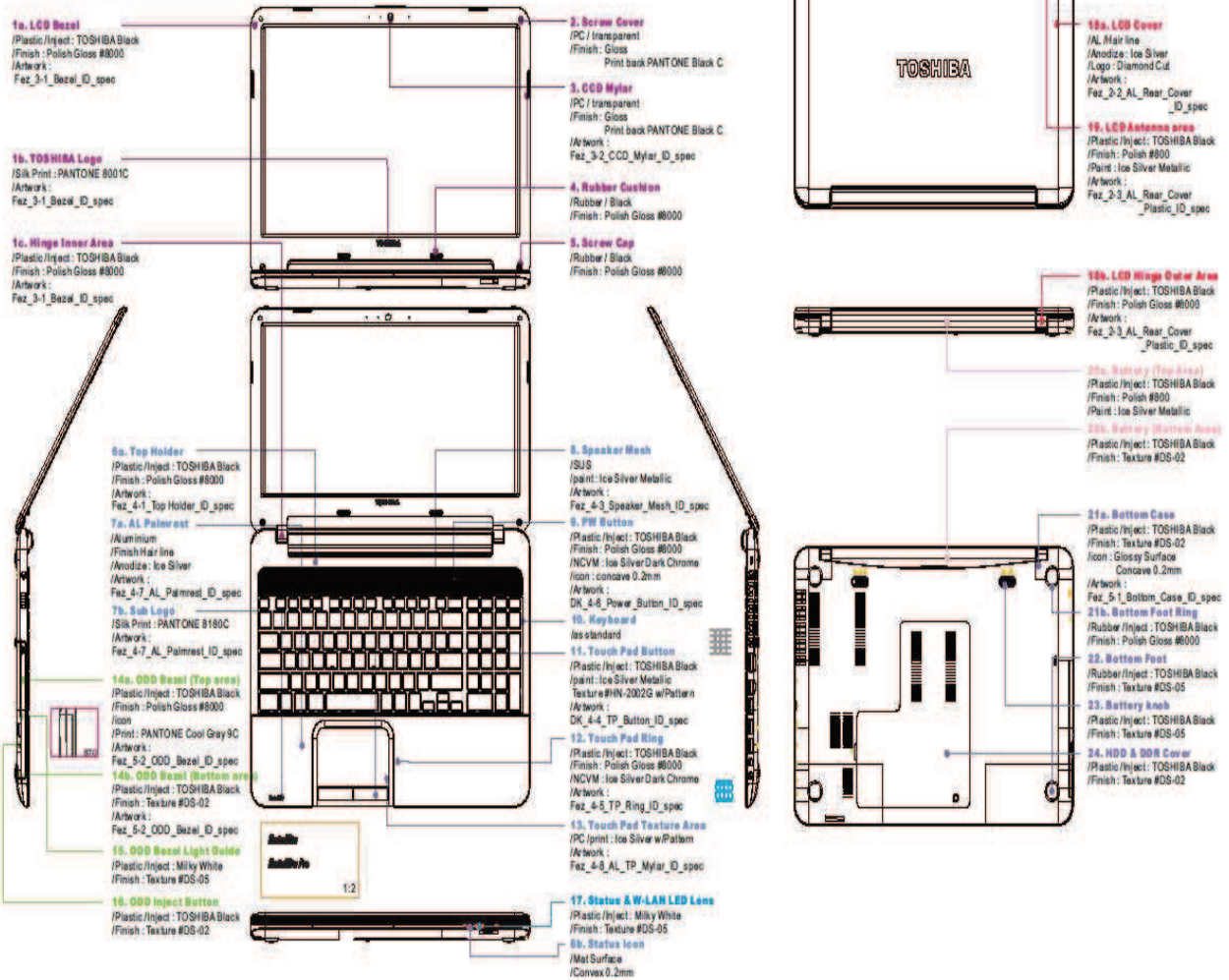

Figure 1-1 ID Parts Description Placement

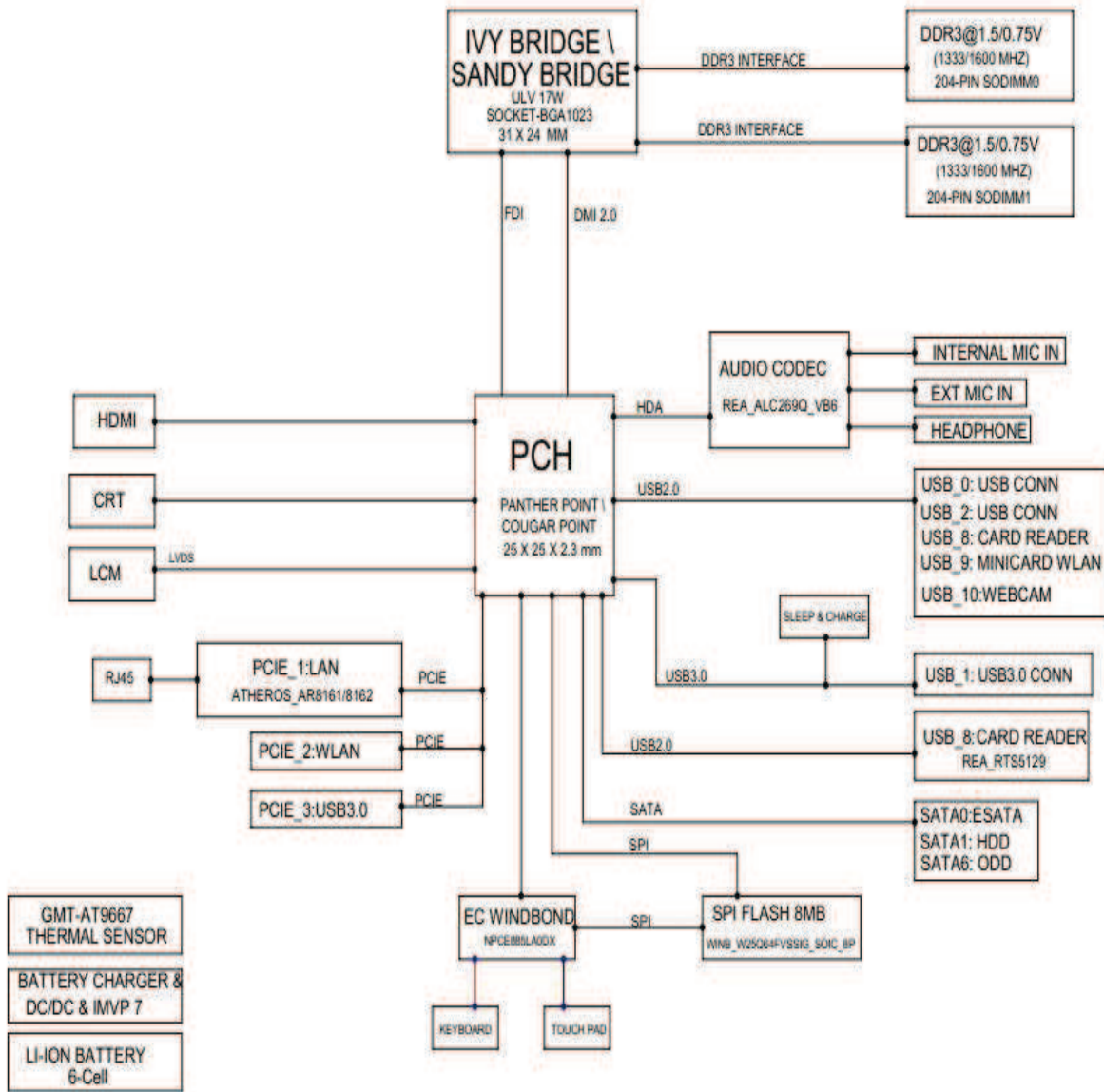

Figure 1-2 Computer Block Diagram



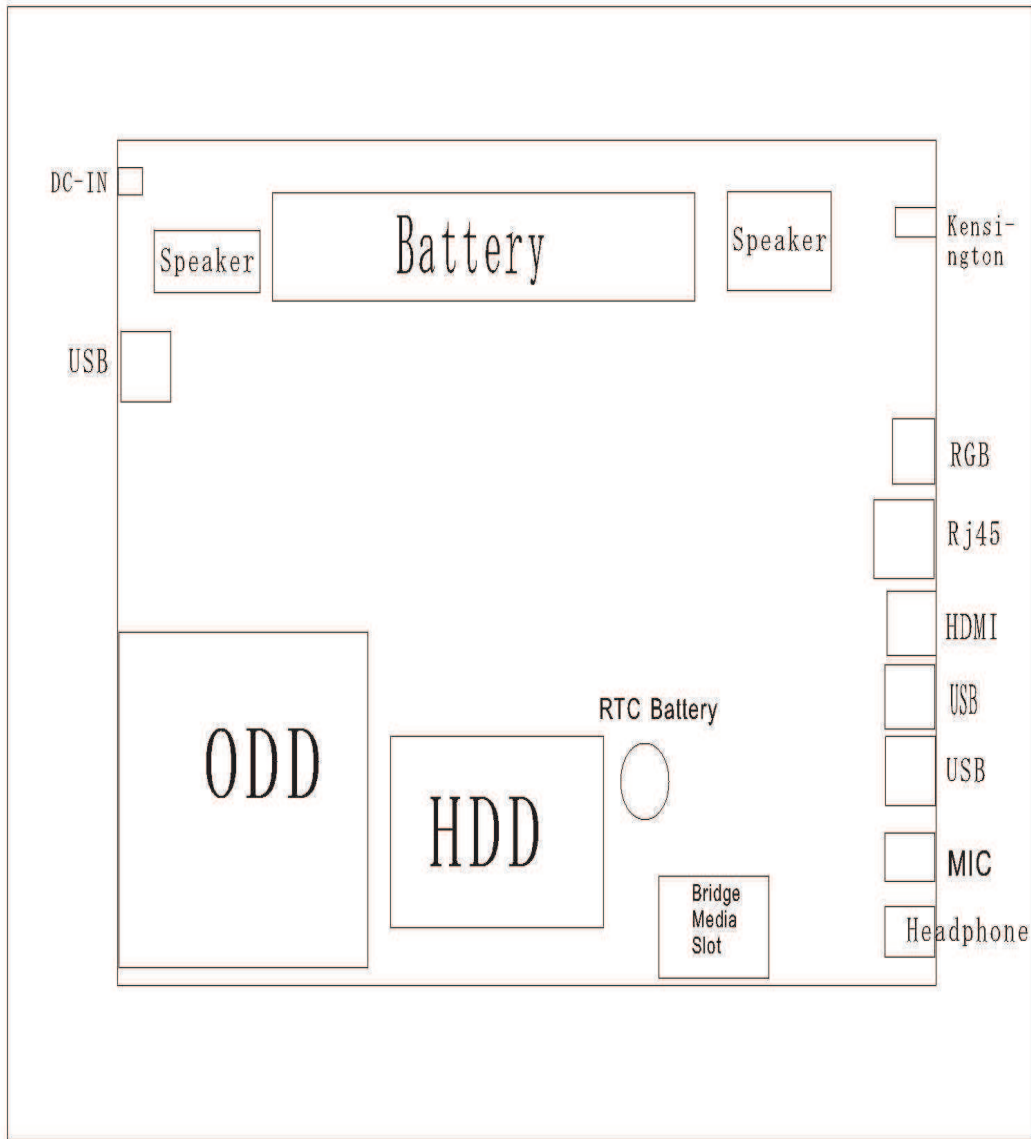

Figure 1-3 System Board Configurations

## 1.2 System Unit Components

Figure 1-4 is Block Diagram of the System Unit.

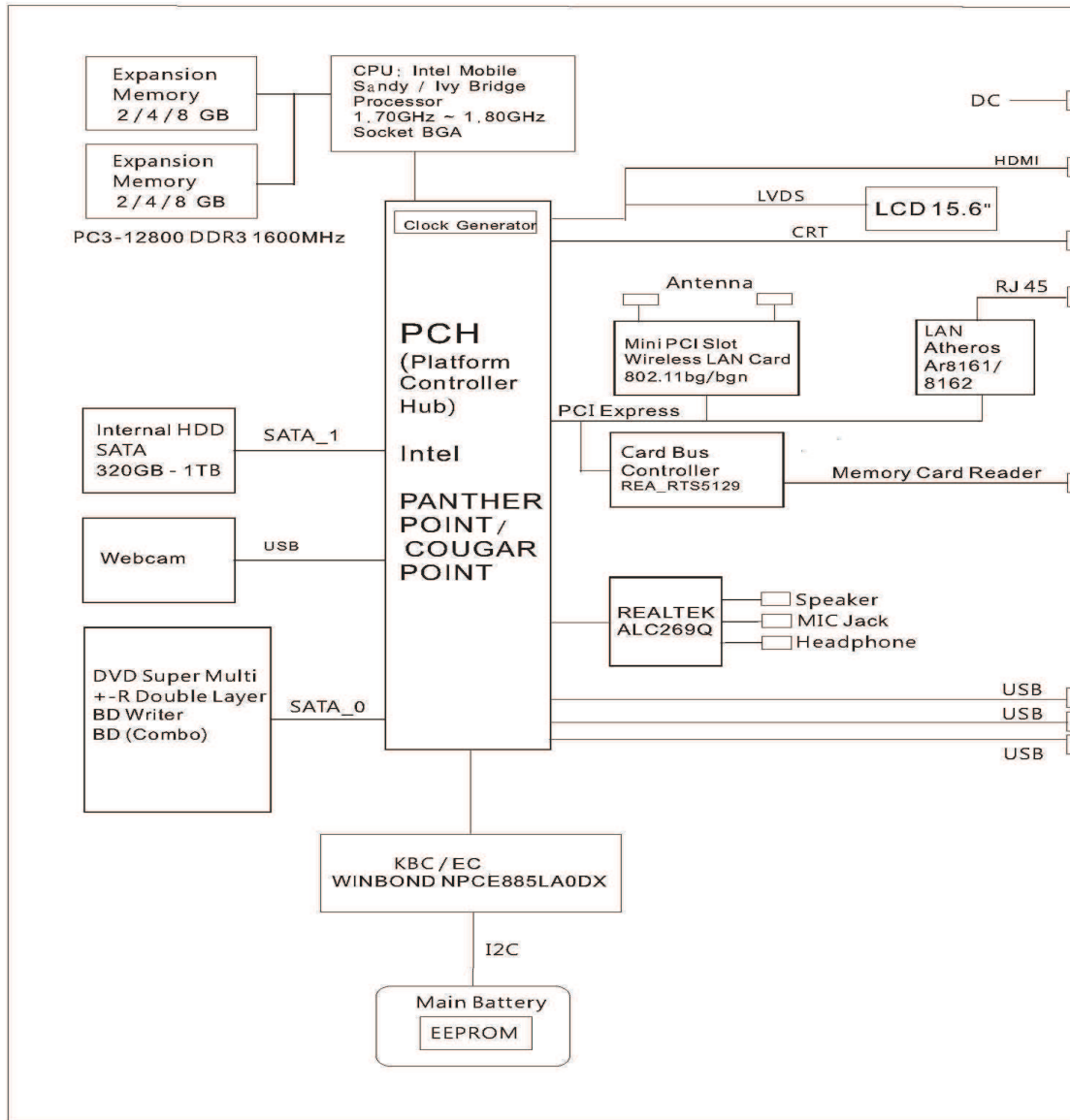

Figure 1-4 System Unit Block Diagram

The system unit of the computer consists of the following components:

- ❑ Processor: Mobile Intel Sandy and Ivy Bridge Processor.
  - Intel Core i5 Processor (FSB, 1600MHz)
    - Core Speed: 1.7 GHz
    - System Bus: 1600 MHz
    - Intel smart Cache: 3 MB
  - Intel Core i3 Processor (FSB, 1600MHz)
    - Core Speed: 1.8 GHz
    - System Bus: 1600 MHz
    - Intel smart Cache: 3 MB
  
- ❑ Memory: Two expansion memory slots are provided. They can hold 2/4/8 GB memory modules available as options to grow up to 16GB.
  - PC3-12800(1600MHz) DDR3 SDRAM supported
  - 2048/4096/8192MB modules supported
    - 2048 MB (256M x 64)
    - 4096 MB (512M x 64)
    - 8192 MB (1024M x 64)
  - DDR3 1.5 volt operation
  - No parity bit
  - 64-bit data transfer
  
- ❑ BIOS ROM (Flash EEPROM)
  - 8Mb x 1 chip (8192KB flash parts)
    - NvStorage Size : 184K
    - NvStorage Free Space : 176K
    - FV00 Size : 4132K
    - FV00 Free Space : 2474K
    - FV01 Size : 576K
    - FV01 Free Space : 202K
    - Micro Code size : 80K
  
- ❑ System Controller
  - Mobile Intel Panther Point Chipset HM70/HM76 PCH
    - Direct Media Interface (DMI)
    - PCI Express Interface

- Integrated Serial ATA (SATA) Host Controller
- Intel High Definition Audio Controller
- Simple Serial Transport (SST) 1.0 Bus
- Platform Environmental Control Interface (PECI)
- Universal Serial Bus (USB) Controller
- Integrated Gigabit LAN Controller
- Intel Active Management Technology with System Defense
- Intel I/O Virtualization (VT-d) Support
- Intel Trusted Execution Technology Support
- Power Management Logic
- Integrated Clock Controller
- Enhanced DMA Controller
- System Management Bus
- High Precision Event Timers
- Timers Based on 82C54
- Real-Time Clock
- System TCO Reduction Circuits
- Serial Peripheral Interface (SPI) Support
- Interrupt Controller
- Firmware Hub Interface Support
- Low Pin Count (LPC) I/F
- GPIO
- Analog and Digit Display Ports
- JTAG Boundary Scan Support

#### ❑ Card Bus Controller

- REALTEK RTS5129
  - Memory Card Reader Controller

#### ❑ Audio Controller

REALTEK ALC269Q integrated audio controller supports multimedia. The sound system features contain the following:

- A stereo DAC that supports 16/20/24-bit widths and 44.1K/48K/96K/192KHz sample rates.
- A stereo ADC that supports 16/20/24-bit widths and 44.1K/48K/96KHz sample rates. The ADC has a gain stage and a stereo one-of-four input selector.
- 2 GPIOs (GPIO0 is External Amplifier Power-Down Signal/ General Purpose I/O. EAPD# is an active-low output /GPIO1 is General Purpose I/O, Class-D Speaker Amplifier Mute Input. SPK\_MUTE# is an active-low input).

- Jack sense detects up to four jacks using only one sense pin
- The Digital Microphone Interface (DMI) is optimized with a hardware DC-level filter, which compensates for digital microphones with DC offset limitations.
- The internal Wake-on-PC-Beep logic resumes the analog paths for the external PC-Beep to propagate through to the output ports.

#### ❑ KBC/EC (Keyboard Controller/Embedded Controller)

A KBC WINBOND NPCE885LA0DX chip is used to serve as KBC/EC and Super IO:

- KBC
  - Scan controller function
  - Interface controller function
- EC
  - Power supply sequence control
  - Overheat shutdown support
  - LED control
  - Beep control
  - Device ON/OFF
  - Cooling fan speed control
  - Universal I/O port
  - Battery capacity check
  - Flash memory reprogramming function
  - EC access interface
  - I2C communication control

#### ❑ Battery EEPROM

- 24C02 equivalent (128 words x 16 bits, I2C interface) integrated in battery pack
  - Storing records of battery use

#### ❑ Clock Generator

- Intel Panther Point Chipset HM70/HM76 Integrated Clock Generator
  - Generating the clock signal required for the system

#### ❑ LAN Controller

- Atheros\_AR8161 - 10/100Mbit / AR8162-10/100Mbit/1Gbit

- IEEE 802.3 10BASE-T/100BASE-TX compliant physical layer interface
- IEEE 802.3u Auto-Negotiation support
- Digital Adaptive Equalization control
- 10BASE-T auto-polarity correction
- LAN Connect interface
- Automatic detection of “unplugged mode”
- Remote boot (PXE 2.1)
- Smart power down when link is not detected

□ Wireless LAN Controller

- Support following 2 kinds of mini PCI wireless LAN cards
  - IEEE 802.11bgn
  - IEEE 802.11abgn
  -
- Data Rate
  - IEEE 802.11bg: Standard 54M bps
  - IEEE 802.11abgn: Standard 130M bps
  -
- Frequency Channel
  - IEEE802.11bg: 2.4GHz
  - IEEE802.11abgn: 2.4GHz

## 1.3 2.5-inch HDD

The computer contains an extremely low-profile, lightweight and high-performance HDD. The HDD incorporates 7mm/9.5 mm height magnetic disk and mini-Winchester type magnetic heads. The HDD interface conforms to Serial ATA. Storage capacities supported are 320, 500, 640 & 750 GB and 1TB.

The HDD is shown in Figure 1-5 and some of its specifications are listed in Table 1-1.

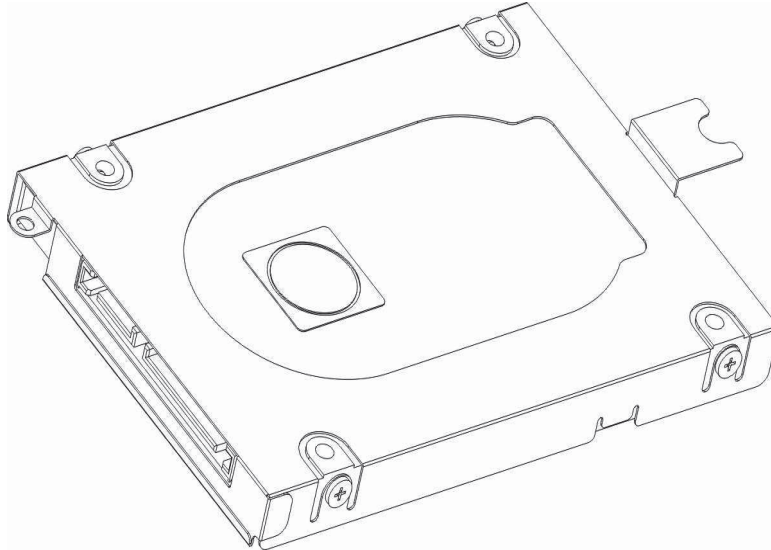

Figure 1-5 SATA HDD

Item	Specifications		
Capacity (GB)	320 GB	500 GB	640 GB
Rotational Speed (RPM)	5400 rpm	5400 rpm	5400 rpm
Height	7mm/9.5 mm	7mm/9.5 mm	9.5 mm
User Data Sectors	625,142,448	976,773,168	1,250,263,728
Bytes / Sector	512	512	512
Item	Specifications		
Capacity (GB)	750 GB	1 TB	-
Rotational Speed (RPM)	5400 rpm	5400 rpm	-
Height	9.5 mm	9.5 mm	-
User Data Sectors	1,465,149,168	1,953,525,168	-
Bytes / Sector	512	512	-

Table 1-1 HDD Specifications

## 1.4 DVD Super Multi (+-R Double Layer)

The DVD Super Multi drive accepts 12-cm (4.72-inch) and 8-cm (3.15-inch) discs. At maximum, the drive can play back a DVD at 8x speed, read CD-ROM at 24x speed, and write CD-R at 24x speed, CD-RW at 4x speed, US CD-RW at 24x speed, High Speed CD-RW at 10x speed, DVD-R at 8x speed, DVD-RW at 6x speed, DVD+R at 8x speed, DVD+R (Double Layer) at 6x speed, DVD-R (Double Layer) at 6x speed, DVD+RW at 8x speed and DVD-RAM at 5x speed.

DVD Super Multi Drive is shown in Figure 1-6 and its specifications are listed in Table 1-2.

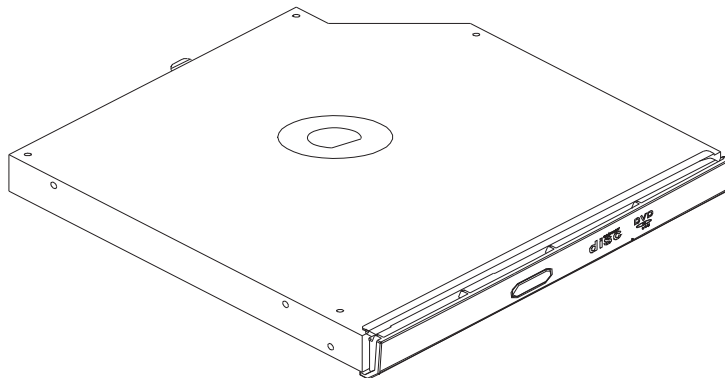

Figure 1-6 DVD Super Multi Drive

Table 1-2 DVD Super Multi Drive Specifications

Item	DVD-ROM mode	CD-ROM mode
Data Transfer Rate (Mbytes/s)	33.3 (U-DMA transfer mode 2) 16.7 (PIO mode 4, Multiword DMA mode 2)	
Access Time (ms) Average Random Access	130 ms	130 ms
Data Buffer Size (Mbytes)	2MB	
Formats Supported	DVD: DVD-VIDEO, DVD-ROM, DVD-R, DVD-RW, DVD-RAM, DVD+R, DVD+-R (Double Layer), DVD+RW. CD: CD-DA, CD-ROM, CD-R, CD-RW, CD-ROMXA, Photo CD (Multi-Session), Video CD, CD-Extra (CD+), CD-Text.	



## 1.5 Blu-Ray Writer

Blu-Ray Writer drive accepts 12-cm (4.72-inch) or 8-cm (3.15-inch) discs. At maximum, it can read CD-ROM at 24x speed, play DVD-ROM at 8x speed, read BD-ROM Video at 1.6x speed, BD-ROM Data at 6x speed, and write CD-R at 24x speed, CD-RW at 4x speed, High Speed CD-RW at 10x speed, Ultra Speed CD-RW at 16x speed, DVD-R at 8x speed, DVD+R at 8x speed, DVD-R DL at 6x speed, DVD+R DL at 6x speed, DVD-RW at 6x speed, DVD+RW at 8x speed, DVD-RAM at 5x speed, BD-R at 6x speed, BD-RE at 2x speed and BD-RE DL at 2x speed.

Blu-Ray Writer Drive is shown in Figure 1-7 and its specifications are listed in Table 1-3.

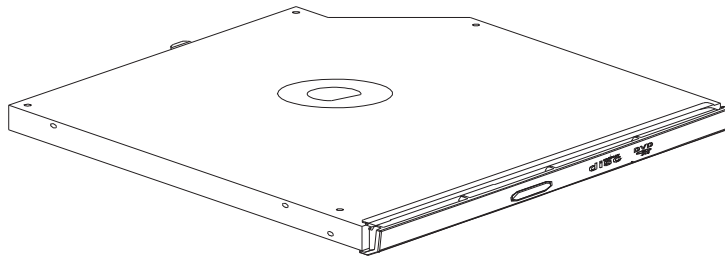

Figure 1-7 Blu-Ray Writer Drive

Table 1-3 Blu-Ray Writer Drive Specifications

Item	BD-ROM Mode	DVD-ROM Mode	CD-ROM Mode
SATA Interface	150 MB/s		
Average Random Access Time	300 ms	190 ms	180 ms
Buffer Memory Size (Mbytes)	2MB		
Formats Supported	BD: BD-ROM, BD-R, BD-RE. DVD: DVD-VIDEO, DVD-ROM, DVD-R, DVD-RW, DVD-R DL, DVD-RAM, DVD+R, DVD+RW, DVD+R DL. CD: CD-DA, CD-ROM, CD-R, CD-RW, CD-ROMXA, Photo CD (Multi-Session), Video CD, CD-Extra (CD+), CD-Text Hybrid SACD.		

## 1.6 Blu-Ray COMBO

Blu-Ray Combo drive accepts 12-cm (4.72-inch) or 8-cm (3.15-inch) discs. At maximum, it can read CD-ROM at 24x speed, play DVD-ROM at 8x speed, read BD-ROM Video at 1.6x speed, BD-ROM Data at 6x speed, and write CD-R at 24x speed, CD-RW at 4x speed, High Speed CD-RW at 10x speed, Ultra Speed CD-RW at 16x speed, DVD-R at 8x speed, DVD+R at 8x speed, DVD-R DL at 4x speed, DVD+R DL at 4x speed, DVD-RW at 6x speed, DVD+RW at 8x speed, DVD-RAM at 5x speed, BD-R at 6x speed and BD-RE at 2x speed.

Blu-Ray Combo Drive is shown in Figure 1-8 and its specifications are listed in Table 1-4.

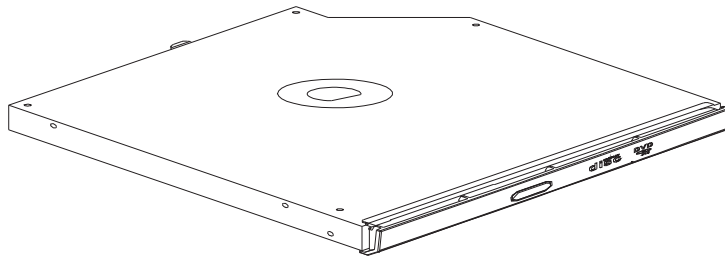

Figure 1-8 Blu-Ray Combo Drive

Table 1-4 Blu-Ray Combo Drive Specifications

Item	BD-RE Mode	DVD+-RW Mode	CD-ROM Mode
SATA Interface	145 MB/s		
Average Random Access Time	300 ms	190 ms	170 ms
Buffer Memory Size (Mbytes)	2MB		
Formats Supported	BD: BD-ROM, BD-R, BD-RE, BD-R Dual, BD-RE Dual. DVD: DVD-VIDEO, DVD-ROM, DVD-R, DVD-RW, DVD-R DL, DVD-RAM, DVD+R, DVD+RW, DVD+R DL. CD: CD-DA, CD-ROM, CD-R, CD-RW, CD-ROMXA, Photo CD (Multi-Session), Video CD, CD-Extra (CD+), CD-Text, SACD Hybrid type.		

## 1.7 Power Supply

The power supply unit provides many different voltages for the system board and performs the following functions:

1. Power input monitor
  - Checks whether the DC power supply (AC adapter) is connected to the computer.
  - Checks whether the battery pack is connected to the computer.
  - Monitors the DC power supply input voltage (AC Adapter output voltage).
2. Power supply's internal control
  - Turns on and off the battery pack charging power supply.
  - Issues a charging current instruction to the PWM control IC of the battery pack charging power supply.
  - Controls the supply of DC power supply input (AC Adapter output) to the power supply unit.
  - Controls the supply of power to the system block (load/logic circuit side).
  - Controls forced shutdown if the power supply malfunctions.
3. Logic circuit control
  - Instructs the gate array to enable/disable tuning the power on.
  - Controls power-on/off operation.
4. Status display
  - Turns on the Power LED (in White).
  - Battery indicator (in White or Amber or Amber Blink).
5. External interface
  - Performs communication through the I2C bus (via the internal EC/KBC).
  - Transfers the power supply operation mode.
6. Output monitor
  - Monitors the voltage output to the system block (load/logic circuit side).
  - Monitors the voltage, over voltage, input/output current of the battery pack.
  - Monitors the internal temperature of the battery pack.
  - Monitors the supply voltage from the AC adapter.

## 1.8 Batteries

The computer has the following 2 types of battery:

- Main Battery Pack
- Real Time Clock (RTC) Battery

Table 1-5 lists the specifications of these batteries.

*Table 1-5 Battery Specifications*

Battery Type		Material	Output voltage	Capacity
Main Battery Pack	4 Cell	Lithium Ion	10.8 V	3000 mAh
RTC Battery		Lithium Ion	3.0 V	210 mAh

### 1.81 Main Battery

The main battery pack serves as the computer's main power source when the AC adapter is not attached. The main battery maintains the state of the computer so that it can resume it.

### 1.82 Battery Charging Control

Battery charging is controlled by TI BQ24725ARGRR. When AC adapter and battery pack are attached to the computer, BQ24725ARGRR controls the charge on/off state and detects a full charge.

- Battery Charge

When the AC adapter is attached, the battery is charged by off-state charge when the system is powered off or by on-state charge when it is powered on.

Table 1-6 Quick/Normal Charging Time

State	Charge Time	
<b>Off-State Charge</b>	4 Cell	About 4 hours max
<b>On-State Charge</b>	4 Cell	About 4~10 hours max

**NOTE:** The time required for normal charge depends on the power consumption by the system. Using the fluorescent lamp and frequently accessing the disk consume much power and lengthen the charge time.

Any of the following cases stops battery charge:

1. The battery becomes fully charged.
2. The AC adapter or battery pack is removed.
3. The battery or AC adapter voltage is abnormal.

#### ❑ Detection of full charge

A full charge is detected only when the battery is being charged by quick or normal charge. A full charge is detected when either of the following conditions is met:

1. The current in the battery charging circuit drops below the predetermined value.
2. The charging time exceeds the fixed limit.

### 1.83 One time RTC Battery

The RTC battery provides power to keep the current date, time and other system information in memory while the computer is turned off.

One time RTC battery is replaceable for service, it can be accessible from under bottom door.

---

# **Chapter 2**

# **Troubleshooting**

---

---

**Chapter 2      Contents**

---

2.1	Outline .....	2-1
2.2	Basic Flowchart.....	2-2
2.3	Power Supply .....	2-7
	Procedure 1 Power Icon Check .....	2-7
	Procedure 2 Connection Check.....	2-8
	Procedure 3 Replacement Check .....	2-8
2.4	System Board.....	2-9
	Procedure 1 Message Check .....	2-9
	Procedure 2 Test Program Check .....	2-10
	Procedure 3 Replacement Check .....	2-10
2.5	HDD.....	2-11
	Procedure 1 Message Check .....	2-11
	Procedure 2 Partition Check .....	2-11
	Procedure 3 Format Check.....	2-12
	Procedure 4 Test Program Check .....	2-13
	Procedure 5 Connector Check and Replacement Check.....	2-14
2.6	Keyboard.....	2-15
	Procedure 1 Test Program Check .....	2-15
	Procedure 2 Connector Check and Replacement Check.....	2-15
2.7	Display .....	2-16
	Procedure 1 External Monitor Check.....	2-16
	Procedure 2 Test Program Check .....	2-16
	Procedure 3 Connector Check and Replacement Check.....	2-16
2.8	ODD (Optical Disk Drive) .....	2-18
	Procedure 1 ODD Cleaning Check .....	2-18
	Procedure 2 Test Program Check .....	2-18
	Procedure 3 Connector Check and Replacement Check.....	2-18
2.9	LAN .....	2-20
	Procedure 1 Test Program Check .....	2-20

---

	Procedure 2 Connector Check and Replacement Check.....	2-20
2.10	Audio Test .....	2-21
	Procedure 1 Test Program Check .....	2-21
	Procedure 2 Connector Check and Replacement Check.....	2-21
2.11	Cooling Module .....	2-22
	Procedure 1 Test Program Check .....	2-22
	Procedure 2 Connector Check and Replacement Check.....	2-22
2.12	Touchpad .....	2-23
	Procedure 1 Test Program Check .....	2-23
	Procedure 2 Connector Check and Replacement Check.....	2-23
2.13	Memory .....	2-24
	Procedure 1 Test Program Check .....	2-24
	Procedure 2 Connector Check and Replacement Check.....	2-24
2.14	USB Port.....	2-25
	Procedure 1 Windows Application Test .....	2-25
	Procedure 2 Connector Check and Replacement Check.....	2-25
2.15	Headphone Port .....	2-26
	Procedure 1 Windows Application Test .....	2-26
	Procedure 2 Connector Check and Replacement Check.....	2-26
2.16	Microphone Port .....	2-27
	Procedure 1 Windows Application Test .....	2-27
	Procedure 2 Connector Check and Replacement Check.....	2-27
2.17	Video RGB Port.....	2-28
	Procedure 1 Windows Application Test .....	2-28
	Procedure 2 Connector Check and Replacement Check.....	2-28
2.18	Card Reader .....	2-29
	Procedure 1 Windows Application Test .....	2-29
	Procedure 2 Connector Check and Replacement Check.....	2-29
2.19	Camera .....	2-30
	Procedure 1 Windows Application Test .....	2-30
	Procedure 2 Connector Check and Replacement Check.....	2-30



## ***2 Troubleshooting***

---

2.20	Wireless LAN .....	2-31
	Procedure 1 Windows Application Test .....	2-31
	Procedure 2 Connector Check and Replacement Check.....	2-31
2.21	Battery Pack.....	2-32
	Procedure 1 Windows Application Test .....	2-32
	Procedure 2 Connector Check and Replacement Check.....	2-32
2.22	HDMI Port.....	2-33
	Procedure 1 Windows Application Test .....	2-33
	Procedure 2 Connector Check and Replacement Check.....	2-33

**Figures**

Figure 2-1 Basic Flowchart (1/2)..... 2-3

**Tables**

Table 2-1 HDD Error Code and Status..... 2-13



## 2.1 Outline

This chapter describes the fault diagnosis procedures for field replaceable units (FRUs) in the computer.

The FRUs covered here are as follows:

- |                     |                     |                    |
|---------------------|---------------------|--------------------|
| 1. System Board     | 2. HDD              | 3. Keyboard        |
| 4. Display          | 5. ODD Drive        | 6. LAN             |
| 7. Speaker          | 8. Cooling Module   | 9. Touchpad        |
| 10. Memory          | 11. USB Port        | 12. Headphone Port |
| 13. Microphone Port | 14. Video RGB Port. | 15. Card Reader    |
| 16. Camera          | 17. Wireless LAN    | 18. Battery Pack   |
| 19. HDMI port       |                     |                    |

See Chapter 4 for the procedures to replace FRUs and Chapter 3 for the procedures to use test programs.

The following tools are required to perform the diagnostic procedures:

1. Diagnostics (maintenance test program) disk
2. Screwdrivers (2.0mm/3mm/3.5mm)
3. Cleaning disk kit (for ODD drive cleaning)
4. Bootable CD
5. Multi-meter
6. External monitor
7. Headphone
8. Microphone
9. A-BEX TEST DVD
10. Music CD
11. DVD TSD-1 (TOSHIBA EMI DVD Test Media)

## 2.2 Basic Flowchart

The basic flowchart in Figure 2-1 serves as a guide for identifying a possibly faulty FRU.

Before going through the diagnostic flowchart steps, verify the following:

- Ask the user if a password has been registered and, if so, ask him or her to enter the password. If the user has forgotten the system password, use a jump wire to make a short circuit on M/B **B500** location (near the RAM module area of PCB), then turn the computer power on. When booted, the computer overrides password protection and automatically erases the current password.
- Make sure the Windows® 7 or Windows® 8 has been installed on the HDD. Any other operating system can cause the computer to malfunction.
- Make sure any piece of optional equipment has been installed.

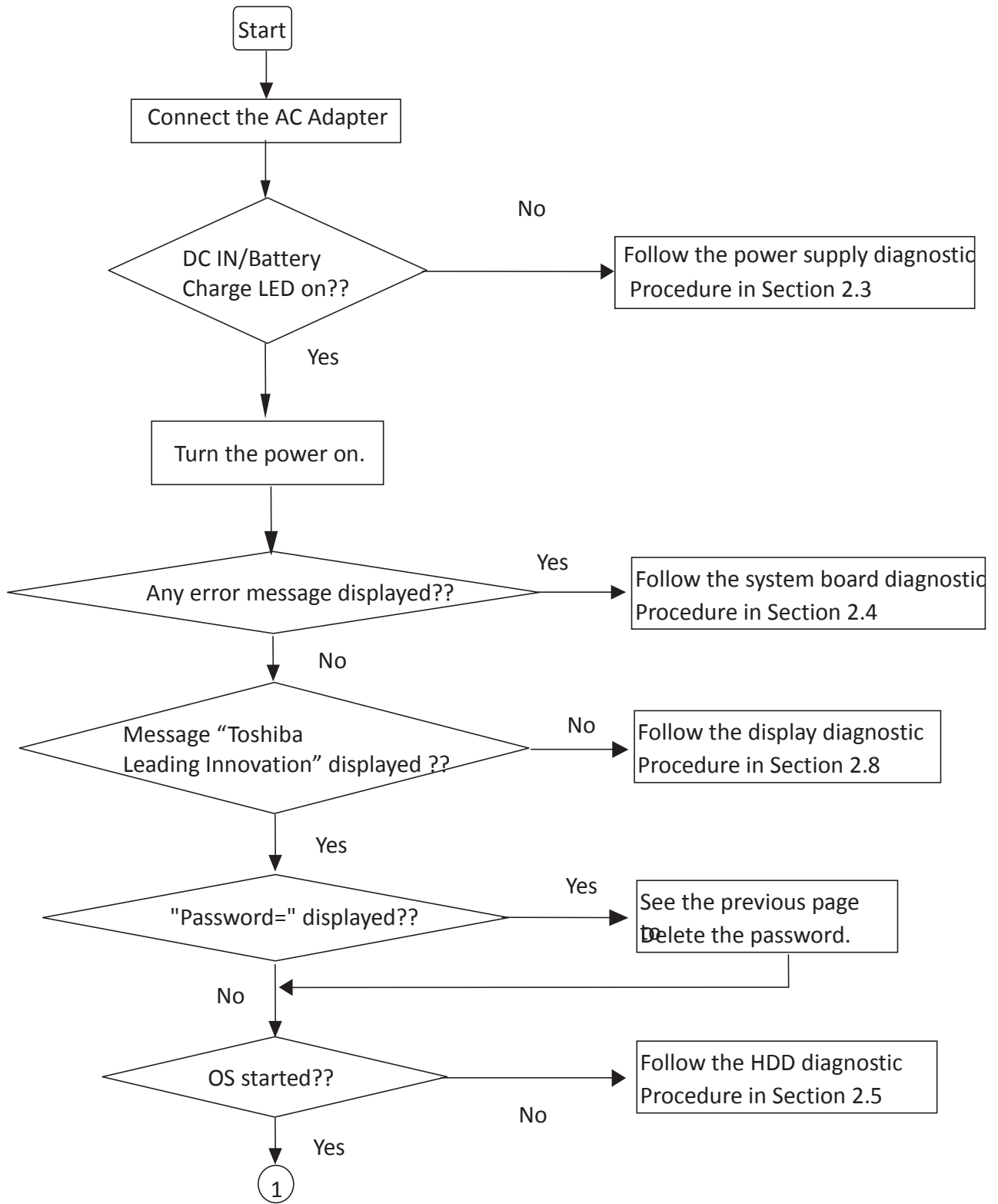

Figure 2-1 Basic Flowchart (1/2)

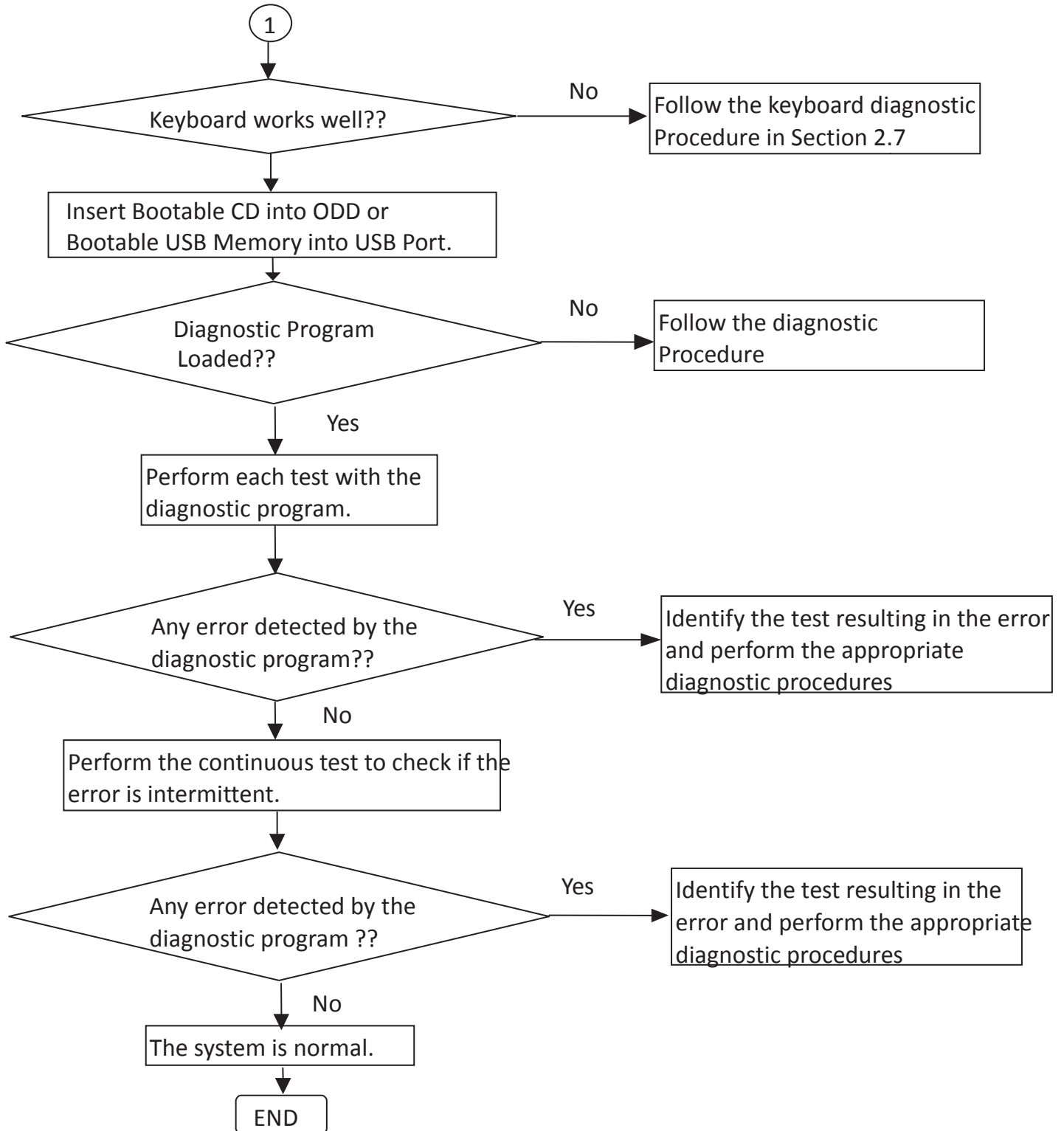

Figure 2-1 Basic Flowchart (2/2)

If the diagnostic program cannot detect an error, the error may be intermittent. Run the continuous test program repeatedly to isolate the problem. Check the log utilities function to confirm which diagnostic test detected the error, then perform the appropriate troubleshooting procedures as follows:

1. If an error is detected by the System test, follow the system board troubleshooting procedures in Section 2.4.
2. If an error is detected by the Hard Disk test, follow the HDD troubleshooting procedures in Section 2.5.
3. If an error is detected by the Keyboard test, follow the keyboard troubleshooting procedures in Section 2.6.
4. If an error is detected by the Display test, follow the display troubleshooting procedures in Section 2.7.
5. If an error is detected by the ODD test, follow the ODD troubleshooting procedures in Section 2.8.
6. If an error is detected by the LAN test, follow the LAN troubleshooting procedures in section 2.9.
7. If an error is detected by the Audio test, follow the Audio troubleshooting procedures in section 2.10.
8. If an error is detected by the Fan On/Off test, follow the cooling module troubleshooting procedures in Section 2.11.
9. If an error is detected by Touchpad test, follow Touchpad troubleshooting procedures in Section 2.12.
10. If an error is detected by Memory test, follow Memory troubleshooting procedures in Section 2.13.
11. If an error is detected by USB test, follow USB port troubleshooting procedures in Section 2.14.
12. If an error is detected by Headphone test, follow Headphone port troubleshooting procedures in Section 2.15.
13. If an error is detected by Microphone test, follow Microphone troubleshooting procedures in Section 2.16.
14. If an error is detected by Video test, follow Video RGB port troubleshooting procedures in Section 2.17.
15. If an error is detected by Card Reader test, follow Card Reader troubleshooting procedures in Section 2.18.
16. If an error is detected by Camera test, follow Camera troubleshooting procedures in Section 2.19.
17. If an error is detected by Wireless LAN test, follow Wireless LAN troubleshooting procedures in Section 2.20.
18. If an error is detected by Battery test, follow Battery troubleshooting procedures in Section 2.21.
19. If an error is detected by HDMI test, follow HDMI port troubleshooting procedures in Section 2.22.

Some components can't be tested and verified by the diagnostic programs, please execute the specified Function Programs in Windows for these components, then perform the



appropriate troubleshooting procedures as described in Section 2.14 to Section 2.22 for these components.

## 2.3 Power Supply

The power supply in the computer controls many functions and components. To check if the power supply is defective or malfunctioning, follow the troubleshooting procedures below as instructed.

- Procedure 1 Power Icon Check
- Procedure 2 Connection Check
- Procedure 3 Replacement Check

### Procedure 1 Power Icon Check

The following power LED indicates the power supply status:

- DC IN/Battery Charge LED

The power supply controller displays the power supply status through the DC IN/Battery Charge LED as in the tables below.

- DC IN/Battery Charge LED

DC IN/Battery Charge LED	Power supply status
On in White	Both DC Power is been supplying from AC Adapter and Battery is fully Charged.
On in Amber	Battery is been Charging from AC Adapter.
Blinking in Amber (at equal intervals)	Battery low while driving the computer.
Off	Battery damage or Else.

If the DC IN/Battery Charge LED is off, follow the steps below:

1. Remove the battery pack and the AC adapter to shut off power supply to the computer.
2. Attach the battery and AC adapter back again.

If the DC IN/Battery Charge LED is still off, follows the steps below:

- Check 1 Make sure the DC IN/Battery Charge LED goes on in White or Amber. If it does not, go to Procedure 2.
- Check 2 Make sure the DC IN/Battery Charge LED goes on in White or Amber again. If it does not, go to Procedure 3.

**Procedure 2 Connection Check**

Power is supplied to the system board as illustrated below:

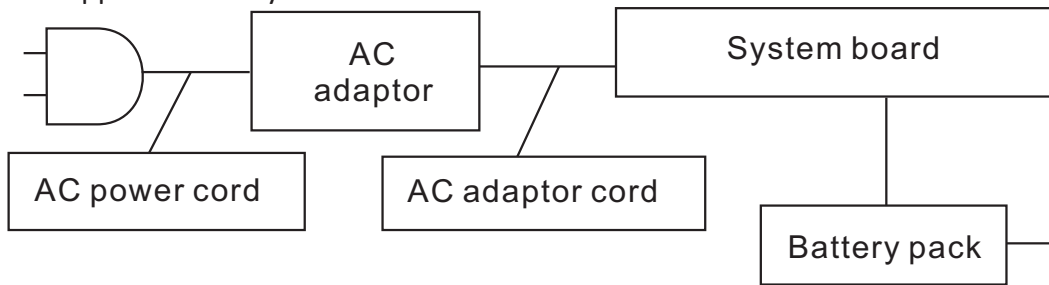

Follow the steps below to check whether each connector has been connected correctly:

- Check 1** Make sure the AC adaptor and AC power cord have been firmly plugged into the DC IN socket and wall outlet, respectively. When they have been connected correctly, perform Check 2.
- Check 2** Connect a new AC adaptor and AC power cord.
- Check 3** Make sure the battery pack has been correctly installed in the computer. If the LED does not go on while the battery pack has been installed correctly, go to Procedure 3.

**Procedure 3 Replacement Check**

The system board or CPU may be faulty. Disassemble the computer according to Chapter 4 and follow the steps below:

- Check 1** Replace the system board with a new one. If the battery pack is still not working properly, perform Check 2.
- Check 2** Replace the CPU with a new one.

## 2.4 System Board

To check if the system board is defective or malfunctioning, follow the troubleshooting procedures below as instructed.

Procedure 1 Message Check

Procedure 2 Test Program Check

Procedure 3 Replacement Check

### Procedure 1 Message Check

When the power is turned on, the system performs the self-diagnostic Power On Self Test (POST) embedded in the BIOS ROM. The POST tests and initializes each IC on the system board.

- If an error message appears on the display, perform Check 1.
- If there is no error message, go to Procedure 2.
- If FREE-DOS or Windows 7 is loaded normally, go to Procedure 3.

**Check 1** If the following error message is displayed on the screen, press the F1 key as prompted. These errors occur when the system configuration preserved in the RTC memory (generally called CMOS memory) does not match the actual configuration or when the data is lost.

If you press the F1 key as prompted by the message, the TSETUP screen appears to set the system configuration. If the error message appears frequently when the power is turned on, replace the RTC battery. If any other error message is displayed, perform Check 2.

```
*** Bad RTC battery ***  
Check system. Then press [F1] key
```

**Check 2** If the following error message is displayed on the screen, press any key as prompted by the message.

The error message appears when either data stored in RAM to be resumed is lost because the battery has been exhausted or the system board is faulty.

```
*** Resume failure and press any key to continue ***
```

**Procedure 2 Test Program Check**

The maintenance test program contains several programs for diagnosing the system board and CPU. Execute the following test programs using the procedures described in Chapter 3.

1. System test
2. Memory test
3. Keyboard test
4. Display test
5. Hard Disk test
6. Mouse test
7. ODD test
8. Sound test
9. LAN test

If an error is detected during these tests, go to Procedure 3.

**Procedure 3 Replacement Check**

The system board, memory, or CPU may be defective. Disassemble the computer following the steps described in Chapter 4 and replace the system board, memory module or CPU with a new one.

## 2.5 HDD

To check if HDD is defective or malfunctioning, follow the troubleshooting procedures below as instructed.

Procedure 1 Message Check

Procedure 2 Partition Check

Procedure 3 Format Check

Procedure 4 Test Program Check

Procedure 5 Connector Check and Replacement Check

**CAUTION:** *The contents of the HDD will be erased when the HDD diagnostic test or formatting is executed. Save the required contents of the HDD to floppy disks or other storage drive in advance.*

### Procedure 1 Message Check

When the computer's HDD does not function properly, some of the following error messages may appear on the display. Follow the steps below to check the HDD.

**Check 1** If either of the following messages appears, go to Procedure 2. If the following messages do not appear, perform Check 2.

```
Insert system disk in drive
Press any key when ready .....
or
Non-System disk or disk error
Replace and press any key
```

**Check 2** Check SETUP to see if the Hard Disk option has been set to "Not used". If so, choose another setting and restart the computer. If the problem persists, go to Procedure 2.

### Procedure 2 Partition Check

Boot from the DOS system. Perform the following checks:

**Check 1** Type **C:** and press the **Enter** key. If you cannot change to drive C, perform Check 2. If you can change to drive C, perform Check 3.

**Check 2** Type **FDISK** and press the **Enter** key. Choose "Display partition information" from the FDISK menu. If drive C is listed, perform Check 3. If

drive C is not listed, return to the FDISK menu and choose the option to create a DOS partition on drive C. Then restart the computer. If the problem persists, go to Procedure 3.

**Check 3** If drive C is listed as active in the FDISK menu, perform Check 4. If drive C is not listed as active, return to the FDISK menu and choose the option to set the active partition for drive C. Then restart the computer. If the problem persists, perform Check 4.

**Check 4** Enter **DIR C:** and press the **Enter** key. If the following message is displayed, go to Procedure 3. If contents of drive C are listed on the display, perform Check 5.

```
Invalid media type reading drive C
Abort, Retry, Fail?
```

**Check 5** Use the **SYS** command in the DOS system to install system files. If the following message appears on the display, the system files have been transferred to the HDD. Restart the computer. If the problem persists, go to Procedure 3.

```
System transferred
```

**NOTE:** If the computer is running Windows 7 and the hard disk capacity is more than 512 MB, the FDISK program will ask if you need support for a partition larger than 2 GB. Select Y for large partition support; however, be sure to read the precaution regarding access by other operating systems.

### Procedure 3 Format Check

The 2.5-inch HDD is formatted using the low-level format program and the FREE-DOS FORMAT program. Using these programs, follow the steps below to format the HDD.

**Check 1** Enter **FORMAT C:/S/U** to format the HDD and transfer system files. If the following message appears on the display, the HDD has been formatted.

```
Format complete
```

If you cannot format the HDD using the test program, go to Procedure 4.

**Procedure 4 Test Program Check**

Run the HDD test program stored on the maintenance test program disk for all test items.

See Chapter 3 for details on how to use the test program.

If an error is detected during the HDD test, an error code and status will be displayed. The error codes and their status names are listed in Table 2-1. If an error code is not generated and the problem still exists, go to Procedure 5.

*Table 2- 1 HDD Error Code and Status*

<b>Code</b>	<b>Status</b>
1	Get Parameter Fail !
2	Read Old Data Error
3	Write Pattern Error
4	Read Back Data Error
5	Data Compare Error
6	Restore Data Error
7	Read Verify Error
9	Seek Error
10	Disk Controller Self Test Failed
11	Disk Controller Test unexpected interrupt Failed
12	Disk Controller action Test Failed
13	Disk dos not support SMART
14	Disk read attribute threshold error
15	Disk read attribute value error
16	Disk SMART attribute value error



**Procedure 5 Connector Check and Replacement Check**

The HDD or system board may be faulty. Disassemble the computer following the steps described in Chapter 4 and perform the following checks:

**Check 1** Make sure the following connectors have been firmly connected to the HDD, system board and CPU.

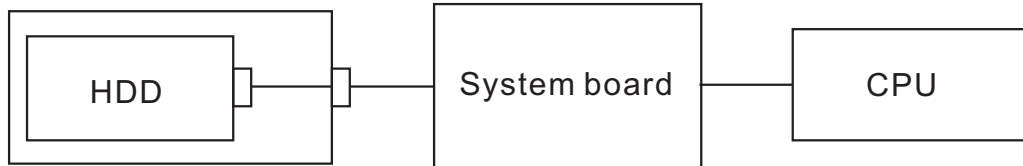

If any connector is loose or off, reconnect it firmly and return to Procedure 1.

If there is still an error, perform Check 2.

**Check 2** The HDD may be damaged. Replace it with a new one following the disassembling instructions in Chapter 4. If the problem persists, perform Check 3.

**Check 3** The System board may be damaged. Replace it with a new one following the disassembling instructions in Chapter 4. If the problem persists, perform Check 4.

**Check 4** The CPU may be damaged. Replace it with a new one following the disassembling instructions in Chapter 4.

## 2.6 Keyboard

To check if the computer's keyboard is defective or malfunctioning, follow troubleshooting procedures below as instructed.

Procedure 1 Test Program Check

Procedure 2 Connector Check and Replacement Check

### Procedure 1 Test Program Check

Execute the Keyboard test available as part of the maintenance test program. See Chapter 3 for information on how to perform the test.

If an error is detected in the test, go to Procedure 2. If no error is detected, the keyboard itself is normal.

### Procedure 2 Connector Check and Replacement Check

The keyboard or system board may be disconnected or faulty. Disassemble the computer following the steps described in Chapter 4 and perform the following checks:

**Check 1**      **Make sure the keyboard cable has been firmly connected to the system board.**

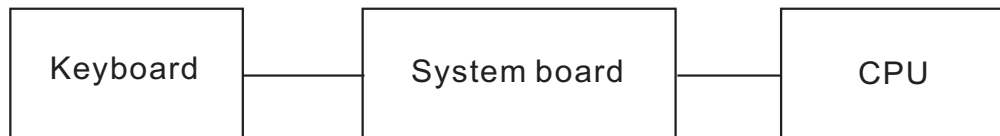

**If the cable is loose or off, reconnect it firmly and return to Procedure 1. If there is still an error, perform Check 2.**

**Check 2**      **The keyboard may be faulty. Replace it with a new one following the instructions in Chapter 4. If the problem persists, perform Check 3.**

**Check 3**      **The System board may be faulty. Replace it with a new one following the instructions in Chapter 4. If the keyboard is still not functioning properly, perform Check 4.**

**Check 4**      **The memory may be defective. Replace the memory module with a new one following the steps described in Chapter 4. If the problem persists, perform Check 5.**

**Check 5**      **The CPU may be faulty. Disassemble the computer following the steps described in Chapter 4 and replace the CPU with a new one.**

## 2.7 Display

To check if the computer's display is defective or malfunctioning, follow the troubleshooting procedures below as instructed.

Procedure 1 External Monitor Check

Procedure 2 Test Program Check

Procedure 3 Connector Check and Replacement Check

### Procedure 1 External Monitor Check

Connect an external monitor to the computer's external monitor port, then boot the computer. The computer automatically detects the external monitor even if resume mode is enabled.

If the external monitor works correctly, the internal LCD or LCD cable may be faulty. Go to Procedure 3.

If the external monitor appears to have the same problem as the internal monitor, the system board may be faulty. Go to Procedure 2.

### Procedure 2 Test Program Check

Insert the diagnostics bootable CD in the computer's CD ROM, turn on the computer and run the test. See Chapter 3 for information on how to perform the test.

If an error is detected in the test, go to Procedure 3. If no error is detected, the display itself is normal.

### Procedure 3 Connector Check and Replacement Check

The display unit has an LCD module, LED Backlight module, panel close switch. Any of the components or their connections may be defective. Disassemble the computer following steps described in Chapter 4, and then perform the following checks:

- (1) If the LCD does not light, perform Check 1.
- (2) If characters or graphics are not displayed normally, perform Check 4.
- (3) If the LCD remains lit when the display is closed, the panel close switch may be defective. Perform Check 5.

**Check 1** Make sure the following cables have been firmly connected to the system board .

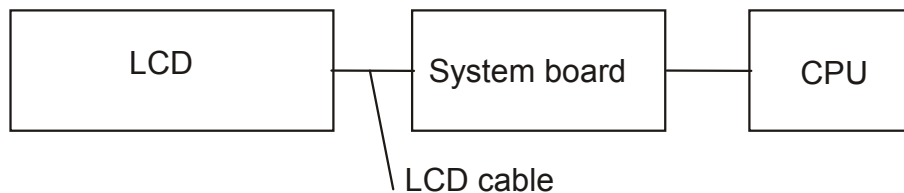

If any of the cables is loose or off, reconnect it firmly and return to Procedure

3. If there is still an error, perform Check 2.
- Check 2** The LCD cable may be faulty. Replace it with a new one and return to Procedure 3. If there is still an error, perform Check 3.
- Check 3** The LCD module may be faulty. Replace it with a new one and return to Procedure 3. If there is still an error, perform Check 4.
- Check 4** The System board may be faulty. Replace it with a new one. If there is still an error, perform Check 5.
- Check 5** The memory may be defective. Replace the memory module with a new one following the steps described in Chapter 4. If the problem persists, perform Check 6.
- Check 6** The CPU may be faulty. Replace it with a new one following the instructions in Chapter 4.

## 2.8 ODD (Optical Disk Drive)

To check if the internal ODD drive is defective or malfunctioning, follow the troubleshooting procedures below as instructed.

Procedure 1 ODD Cleaning Check

Procedure 2 Test Program Check

Procedure 3 Connector Check and Replacement Check

### Procedure 1 ODD Cleaning Check

1. Turn off the power to the computer.
2. Open the ODD tray by inserting a slender object such as a straightened paper clip into the eject hole. The object must be long enough to activate the eject mechanism.
3. Clean the laser pickup lens with a lens cleaner. Apply the cleaner to a cloth and wipe the lens.
4. If the ODD drive still does not function properly after cleaning, go to Procedure 2.

### Procedure 2 Test Program Check

Execute the ODD drive test program available as part of the maintenance test program. Insert the diagnostics CD in the computer's CD, turn on the computer and run the test. Then insert a test ODD (Toshiba-EMI DVD-ROM TEST DISK TSD-1) into the ODD drive. See Chapter 3 for information on how to perform the test.

If any error is detected by the test, go to Procedure 3.

### Procedure 3 Connector Check and Replacement Check

The ODD drive is connected to the system board by the connector. The connector may be disconnected from the system board or faulty. Disassemble the computer following the steps described in Chapter 4 and perform the following checks:

**Check 1** Make sure the following connector has been firmly connected to the ODD drive and the system board.

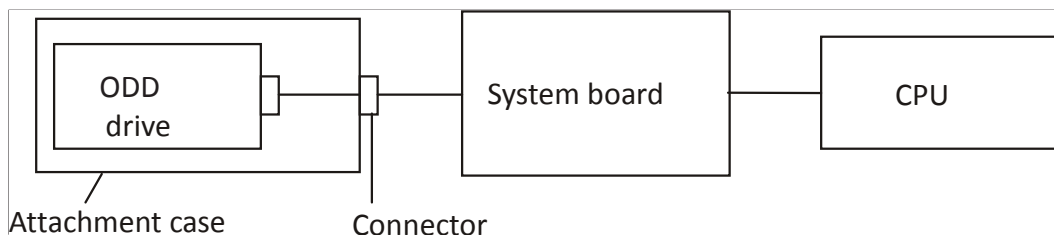

**If the connector is loose or off, reconnect it firmly and return to Procedure 2.**

**If there is still an error, perform Check 2.**

**Check 2** The connector may be faulty. Replace the connector with a new one

- following the steps in Chapter 4. If the ODD drive is still not functioning properly, perform Check 3.
- Check 3** The ODD drive may be faulty. Replace the ODD drive with a new one following the steps in Chapter 4. If the ODD drive is still not functioning properly, perform Check 4.
- Check 4** The system board may be faulty. Replace it with new one following the instructions in Chapter 4. If the ODD drive is still not functioning properly, perform Check 5.
- Check 5** The memory may be defective. Replace the memory module with a new one following the steps described in Chapter 4.

## 2.9 LAN

To check if the computer's LAN is defective or malfunctioning, follow the troubleshooting procedures below as instructed.

Procedure 1 Test Program Check

Procedure 2 Connector Check and Replacement Check

### Procedure 1 Test Program Check

Execute the LAN check program available as part of the maintenance test program. This program will check the LAN. Insert the Bootable CD into the CD. Turn on the computer and run the check program. See Chapter 3 for information on how to perform the check.

If any abnormal is detected by the check, go to Procedure 2

### Procedure 2 Connector Check and Replacement Check

The LAN connector (RJ45) is mounted on the system board. If the LAN malfunctions, the system board or CPU might be faulty.

Disassemble the computer following the steps described in Chapter 4 and perform the following checks:

- Check 1**      **The system board may be faulty. Replace it with a new one following the instructions in Chapter 4. If the LAN is still not functioning properly, perform Check 2.**
- Check 2**      **The memory may be defective. Replace the memory module with a new one following the steps described in Chapter 4. If the problem persists, perform Check 3.**
- Check 3**      **The CPU may be faulty. Disassemble the computer following the steps described in Chapter 4 and replace the CPU with a new one.**

## 2.10 Audio Test

To check if the computer's Speaker is defective or malfunctioning, follow troubleshooting procedures below as instructed.

Procedure 1 Test Program Check

Procedure 2 Connector Check and Replacement Check

### Procedure 1 Test Program Check

Execute the Audio test available as part of the maintenance test program. See Chapter 3 for information on how to perform the test.

If an error is detected in the test, go to Procedure 2. If no error is detected, the Audio itself is normal.

### Procedure 2 Connector Check and Replacement Check

The Audio or system board may be disconnected or faulty. Disassemble the computer following the steps described in Chapter 4 and perform the following checks:

**Check 1** Make sure the Speaker cable has been firmly connected to the system board.

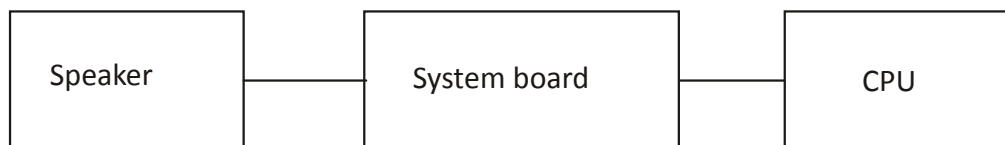

If the cable is loose or off, reconnect it firmly and return to Procedure 1. If there is still an error, perform Check 2.

**Check 2** The Speaker may be faulty. Replace it with a new one following the instructions in Chapter 4. If the problem persists, perform Check 3.

**Check 3** The System board may be faulty. Replace it with a new one following the instructions in Chapter 4. If the Audio is still not functioning properly, perform Check 4.

**Check 4** The memory may be defective. Replace the memory module with a new one following the steps described in Chapter 4. If the problem persists, perform Check 5.

**Check 5** The CPU may be faulty. Disassemble the computer following the steps described in Chapter 4 and replace the CPU with a new one.



## 2.11 Cooling Module

To check if the computer's cooling module is defective or malfunctioning, follow the troubleshooting procedures below as instructed.

Procedure 1 Test Program Check

Procedure 2 Connector Check and Replacement Check

### Procedure 1 Test Program Check

Execute the Fan On/off test program available as part of the maintenance test program. This test program checks the cooling module. Insert the diagnostics bootable CD in the computer's CD, turn on the computer and run the test. See Chapter 3 for information on how to perform the test.

If any error is detected by the test, go to Procedure 2.

### Procedure 2 Connector Check and Replacement Check

The cooling module is connected to the system board. If the cooling module malfunctions, there may be a bad connection between the cooling module and the system board or either might be faulty.

Disassemble the computer following the steps described in Chapter 4 and perform the following checks:

**Check 1**     **Make sure the cooling module has been firmly connected to the connector on the system board. Also make sure that the tape is not stuck to any part of the fan and that the fan is free of foreign matter.**

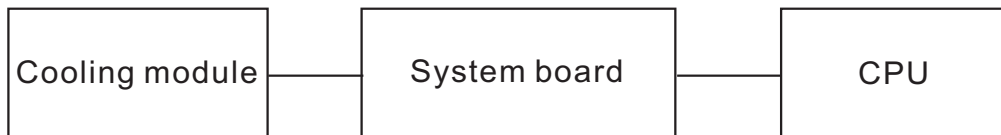

If the connector is disconnected, connect it firmly to the system board and return to Procedure 1. If the tape is stuck to any part of the fan, stick it back to the specified point. If a foreign matter is found in the fan, remove it and then return to Procedure 1. If there is still an error, perform Check 2.

**Check 2**     **The cooling module may be faulty. Replace it with a new one following the steps in Chapter 4. If the cooling module is still not functioning properly, perform Check 3.**

**Check 3**     **The memory may be defective. Replace the memory module with a new one following the steps described in Chapter 4. If the problem persists, perform Check 4.**

**Check 4**     **The CPU may be faulty. Disassemble the computer following the steps described in Chapter 4 and replace the CPU with a new one.**

## 2.12 Touchpad

To check if the computer's Touchpad is defective or malfunctioning, follow troubleshooting procedures below as instructed.

Procedure 1 Test Program Check

Procedure 2 Connector Check and Replacement Check

### Procedure 1 Test Program Check

Execute Touchpad Test Program available as part of the maintenance test program. This test program checks Touchpad Module. Insert the diagnostics bootable CD in the computer's CD/DVD device, turn on the computer and run the test. See Chapter 3 for information on how to perform the test. If any error is detected by the test, go to Procedure 2. If an error is not located, Touchpad itself is normal.

### Procedure 2 Connector Check and Replacement Check

Touchpad Module is connected to the system board through FPC Cable. If Touchpad Module malfunctions, there may be a bad connection between Touchpad Module and System Board, or either might be faulty. Disassemble the computer following the steps described in Chapter 4 and perform the following checks:

**Check 1**      **Make sure Touchpad Module has been firmly connected to the connector on System Board. Also make sure the tape is not stuck to any part of Touchpad Module and Touchpad Module is free of foreign matters.**

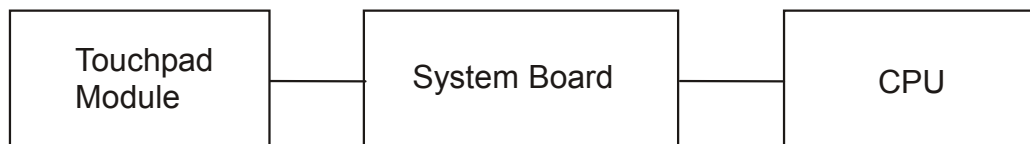

And if the connector is disconnected, connect it firmly to the system board and return to Procedure 1. If the tape is stuck to any part of Touchpad, stick it back to the specified point and if a foreign matter is found on Touchpad, remove it and then return to Procedure 1. If there is still an error, perform Check 2.

**Check 2**      **Touchpad Module may be faulty. Replace it with a new one following the steps described in Chapter 4. If Touchpad Module replaced is still not functioning properly, perform Check 3.**

**Check 3**      **System Board may be defective. Replace System Board with a new one following the steps described in Chapter 4. If the problem persists, perform Check 4.**

**Check 4**      **CPU may be faulty. Disassemble the computer following the steps described in Chapter 4 and replace CPU with a new one.**

## 2.13 Memory

To check if the computer's Memory Module is defective or malfunctioning, follow the troubleshooting procedures below as instructed.

Procedure 1 Test Program Check

Procedure 2 Connector Check and Replacement Check

### Procedure 1 Test Program Check

Execute Memory Test Program available as part of the maintenance test program. This test program checks the memory module. Insert the diagnostics bootable CD in the computer's CD/DVD device, turn on the computer and run the test. See Chapter 3 for information on how to perform the test. If any error is detected by the test, go to Procedure 2. If no error is detected, Memory Module is functioning properly.

### Procedure 2 Connector Check and Replacement Check

The memory module is connected to the system board. If the memory module malfunctions, there may be a bad connection between Memory Module and System Board, or either might be faulty. Disassemble the computer following the steps described in Chapter 4 and perform the following checks:

**Check 1** Make sure Memory Module has been firmly connected to the connector on System Board. Also make sure the tape is not stuck to any part of Memory Module and Memory Module is free of foreign matters.

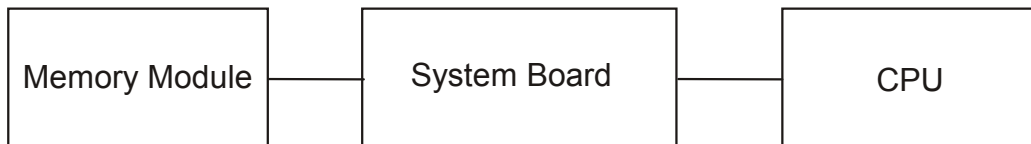

And if the connector is disconnected, connect it firmly to the system board and return to Procedure 1. If the tape is stuck to any part of memory, stick it back to the specified point and if a foreign matter is found on memory, remove it and then return to Procedure 1. If there is still an error, perform Check 2.

**Check 2** Memory Module may be faulty. Replace it with a new one following the steps described in Chapter 4. If Memory Module replaced is still not functioning properly, perform Check 3.

**Check 3** System Board may be defective. Replace System Board with a new one following the steps described in Chapter 4. If the problem persists, perform Check 4.

**Check 4** CPU may be faulty. Disassemble the computer following the steps described in Chapter 4 and replace CPU with a new one.

## 2.14 USB Port

To determine if the computer's USB Port is functioning properly or malfunctions, perform following procedures. Start with Procedure 1 and continue with the other procedure as instruction below.

Procedure 1 Windows Application Test

Procedure 2 Connector Check and Replacement Check

### Procedure 1 Windows Application Test

The USB Port Connector is mounted on System Board. Connect a USB device with USB interface to the computer's USB port, then power on the computer into Windows. The computer will automatically detect this USB device through USB Port. If the USB device appears to have a certain problem, go to Procedure 2. If an error is not located, USB Port is functioning properly.

### Procedure 2 Connector Check and Replacement Check

If USB Port on System Board malfunctions, there may be a bad connection between USB device and System Board, or either of System Board and CPU might be faulty. Disassemble the computer following the steps described in Chapter 4 and perform the following checks:

**Check 1** Make sure USB device cable has been firmly connected to USB Port of System Board. Also make sure USB Port on System Board is free of foreign matters.

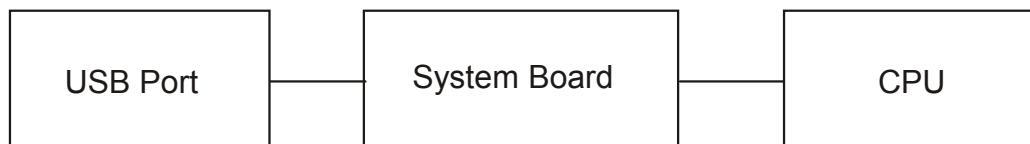

And if the connector is disconnected, connect it firmly to the system board and return to Procedure 1. If a foreign matter is found on USB Port of System Board, remove it and then return to Procedure 1. If the problem persists, perform Check 2.

**Check 2** System Board may be faulty. Replace it with a new one following the steps described in Chapter 4. If USB Port is still not functioning properly, perform Check 3.

**Check 3** CPU may be defective. Disassemble the computer following the steps described in Chapter 4 and replace CPU with a new one.

## 2.15 Headphone Port

To determine if the computer's Headphone Port is functioning properly or malfunctions, perform following procedures. Start with Procedure 1 and continue with the other procedure as instruction below.

Procedure 1 Windows Application Test

Procedure 2 Connector Check and Replacement Check

### Procedure 1 Windows Application Test

Headphone Port Connector is mounted on System Board. Connect external Headphone with Headphone Jack interface to the computer's Headphone Port, then power on the computer into Windows. The computer will automatically detect this Headphone device through Headphone Port. Execute Function Programs in Windows, if the Headphone device appears to have a certain problem, go to Procedure 2. If an error is not located, Headphone Port is functioning properly.

### Procedure 2 Connector Check and Replacement Check

If Headphone Port on System Board malfunctions, there may be a bad connection between Headphone device and System Board, or either of System Board and CPU might be faulty. Disassemble the computer following the steps described in Chapter 4 and perform the following checks:

**Check 1** Make sure Headphone device cable has been firmly connected to Headphone Port of System Board. Also make sure Headphone Port on System Board is free of foreign matters.

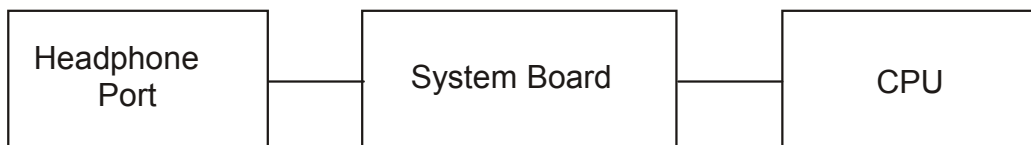

And if the connector is disconnected, connect it firmly to the system board and return to Procedure 1. If a foreign matter is found on Headphone Port of System Board, remove it and then return to Procedure 1. If the problem persists, perform Check 2.

**Check 2** System Board may be faulty. Replace it with a new one following the steps described in Chapter 4. If Headphone Port is still not functioning properly, perform Check 3.

**Check 3** CPU may be defective. Disassemble the computer following the steps described in Chapter 4 and replace CPU with a new one.

## 2.16 Microphone Port

To determine if the computer's Microphone Port is functioning properly or malfunctions, perform following procedures. Start with Procedure 1 and continue with the other procedure as instruction below.

Procedure 1 Windows Application Test

Procedure 2 Connector Check and Replacement Check

### Procedure 1 Windows Application Test

Microphone Port Connector is mounted on System Board. Connect external Microphone with Microphone Jack interface to the computer's Microphone Port, then power on the computer into Windows. The computer will automatically detect this Microphone device through Microphone Port. Execute Function Programs in Windows, if the Microphone device appears to have a certain problem, go to Procedure 2. If an error is not located, Microphone Port is functioning properly.

### Procedure 2 Connector Check and Replacement Check

If Microphone Port on System Board malfunctions, there may be a bad connection between Microphone device and System Board, or either of System Board and CPU might be faulty. Disassemble the computer following the steps described in Chapter 4 and perform the following checks:

**Check 1** Make sure Microphone device cable has been firmly connected to Microphone Port of System Board. Also make sure Microphone Port on System Board is free of foreign matters.

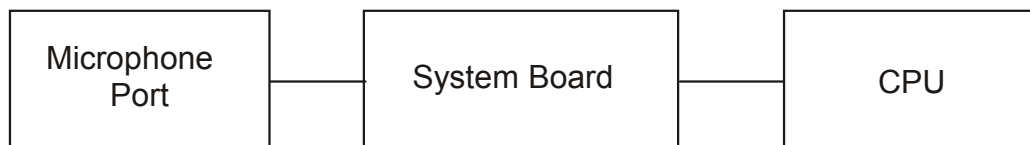

And if the connector is disconnected, connect it firmly to the system board and return to Procedure 1. If a foreign matter is found on Microphone Port of System Board, remove it and then return to Procedure 1. If the problem persists, perform Check 2.

**Check 2** System Board may be faulty. Replace it with a new one following the steps described in Chapter 4. If Microphone Port is still not functioning properly, perform Check 3.

**Check 3** CPU may be defective. Disassemble the computer following the steps described in Chapter 4 and replace CPU with a new one.

## 2.17 Video RGB Port

Video RGB Port Board or System Board may be the reason of Video RGB Port fault. Either of these two components may be damaged. To determine if the computer's Video RGB Port is functioning properly, perform following procedures. Start with Procedure 1 and continue with the other procedure as instruction below.

Procedure 1 Windows Application Test

Procedure 2 Connector Check and Replacement Check

### Procedure 1 Windows Application Test

Video RGB Port Connector is mounted on Video RGB Port Board. Connect an external monitor with RGB interface to the computer's Video RGB port, then power on the computer into Windows. The computer will automatically detect this external monitor through Video RGB Port. If the external monitor appears to have a certain problem, go to Procedure 2. If an error is not located, Video RGB Port is functioning properly.

### Procedure 2 Connector Check and Replacement Check

Video RGB Port Board is connected to System Board through FPC Cable. If Video RGB Port malfunctions, there may be a bad connection between Video RGB Port Board and System Board, or either might be faulty. Disassemble the computer following the steps described in Chapter 4 and perform the following checks:

**Check 1**      **Make sure Video RGB Port Board FPC Cable has been firmly connected to the connector on System Board. Also make sure Video RGB Board is free of foreign matters.**

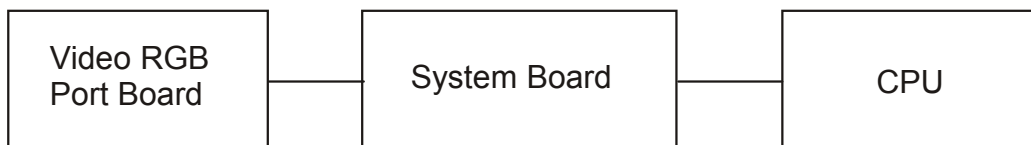

And if the connector is disconnected, connect it firmly to the system board and return to Procedure 1. If a foreign matter is found on Video RGB Port Board, remove it and then return to Procedure 1. If the problem persists, perform Check 2.

**Check 2**      **Video RGB Port Board may be faulty. Replace it with a new one following the steps described in Chapter 4. If Video RGB Port Board replaced is still not functioning properly, perform Check 3.**

**Check 3**      **System Board may be defective. Replace System Board with a new one following steps described in Chapter 4.**

## 2.18 Card Reader

Card Reader Board or System Board may be the reason of Card Reader fault. Either of these two components may be damaged. To determine if the computer's Card Reader is functioning properly, perform following procedures. Start with Procedure 1 and continue with the other procedure as instruction below.

Procedure 1 Windows Application Test

Procedure 2 Connector Check and Replacement Check

### Procedure 1 Windows Application Test

Put a Memory Card into Card Reader Slot, then power on the computer into Windows. The computer will automatically detect this memory card through Card Reader Slot. Execute Function Programs in Windows, if the memory card is not functioning properly, go to Procedure 2. If an error is not located, Card Reader system is functioning properly.

### Procedure 2 Connector Check and Replacement Check

Card Reader Board is connected to System Board through FPC Cable. If Card Reader malfunctions, there may be a bad connection between Card Reader Board and System Board, or either of these two components might be faulty. Disassemble the computer following the steps described in Chapter 4 and perform the following checks:

**Check 1**      **Make sure Card Reader Board FPC Cable has been firmly connected to the connector on System Board. Also make sure Card Reader Board is free of foreign matters.**

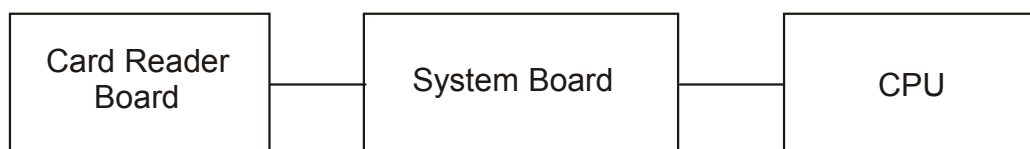

And if the connector is disconnected, connect it firmly to the system board and return to Procedure 1. If a foreign matter is found on Card Reader Board, remove it and then return to Procedure 1. If the problem persists, perform Check 2.

**Check 2**      **Card Reader Board may be faulty. Replace it with a new one following the steps described in Chapter 4. If Card Reader Board replaced is still not functioning properly, perform Check 3.**

**Check 3**      **System Board may be defective. Replace System Board with a new one following the steps described in Chapter 4.**



## 2.19 Camera

Camera Module or System Board may be the reason of Camera fault. Either of these two components may be damaged. To determine if the computer's Camera is functioning properly, perform following procedures. Start with Procedure 1 and continue with the other procedure as instruction below.

Procedure 1 Windows Application Test

Procedure 2 Connector Check and Replacement Check

### Procedure 1 Windows Application Test

Execute Function Programs in Windows, the LED of Camera should be turn on when Camera working, if Camera Module is not functioning properly, go to Procedure 2. If an error is not located, Camera system is functioning properly.

### Procedure 2 Connector Check and Replacement Check

Camera Module is connected to System Board through FPC Cable. If Camera malfunctions, there may be a bad connection between Camera Module and System Board, or either of these two components might be faulty. Disassemble the computer following the steps described in Chapter 4 and perform the following checks:

**Check 1**      **Make sure Camera Module FPC Cable has been firmly connected to the connector on System Board. Also make sure Camera Module is free of foreign matters.**

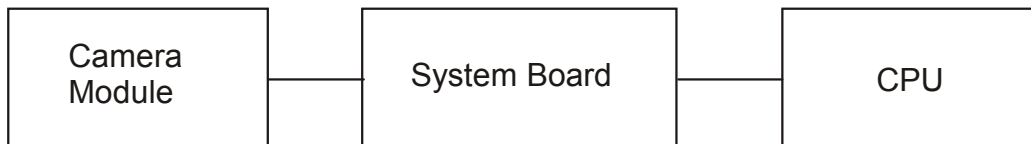

And if the connector is disconnected, connect it firmly to the system board and return to Procedure 1. If a foreign matter is found on Camera Module, remove it and then return to Procedure 1. If the problem persists, perform Check 2.

**Check 2**      **Camera Module may be faulty. Replace it with a new one following the steps described in Chapter 4. If Camera Module replaced is still not functioning properly, perform Check 3.**

**Check 3**      **System Board may be defective. Replace System Board with a new one following the steps described in Chapter 4.**

## 2.20 Wireless LAN

Wireless Module or system board may be the reason of Wireless LAN fault. Either of these two components may be damaged. To determine if the computer's Wireless LAN module is functioning properly, perform following procedures. Start with Procedure 1 and continue with the other procedures as instruction below.

Procedure 1 Windows Application Test

Procedure 2 Connector Check and Replacement Check

### Procedure 1 Windows Application Test

Execute Function Programs in Windows, which will display the Wireless LAN Test Result. If the test and diagnostics result is abnormal, go to Procedure 2. If an error is not located, Wireless LAN system is functioning properly.

### Procedure 2 Connector Check and Replacement Check

Wireless LAN Module is connected to the system board. If Wireless LAN malfunctions, there may be a bad connection between Wireless LAN Module and the system board, or either might be faulty. Disassemble the computer following the steps described in Chapter 4 and perform the following checks:

**Check 1**      **Make sure Wireless LAN module has been firmly connected to the connector on the system board. Also make sure Wireless LAN module is free of foreign matters.**

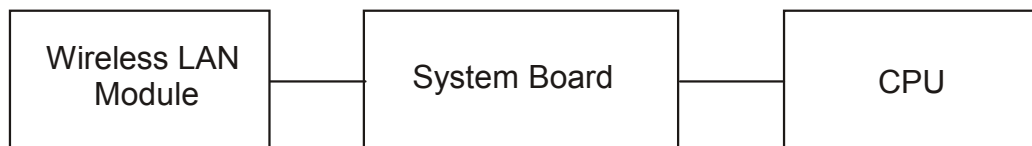

And if the connector is disconnected, connect it firmly to the system board and return to Procedure 1. If a foreign matter is found on Wireless LAN Module, remove it and then return to Procedure 1. If there is still an error, perform Check 2.

**Check 2**      **Wireless LAN Module may be faulty. Replace it with a new one following the steps described in Chapter 4. If Wireless LAN Module replaced is still not functioning properly, perform Check 3.**

**Check 3**      **System Board may be defective. Replace System Board with a new one following the steps described in Chapter 4.**

## 2.21 Battery Pack

Battery Pack or system board may be the reason of Battery fault. Either of these two components may be damaged. To determine if the computer's Battery Pack is functioning properly, perform following procedures. Start with Procedure 1 and continue with the other procedures as instruction below.

Procedure 1 Windows Application Test

Procedure 2 Connector Check and Replacement Check

### Procedure 1 Windows Application Test

Execute Function Programs in Windows, which will display the Battery Pack Test Result. If the test and diagnostics result is abnormal, go to Procedure 2. If an error is not located, Battery Pack system is functioning properly.

### Procedure 2 Connector Check and Replacement Check

Battery Pack is connected to the system board. If Battery Pack malfunctions, there may be a bad connection between Battery Pack and the system board, or either might be faulty. Disassemble the computer following the steps described in Chapter 4 and perform the following checks:

**Check 1** Make sure Battery Pack has been firmly connected to the connector on the system board. Also make sure Battery Pack is free of foreign matters.

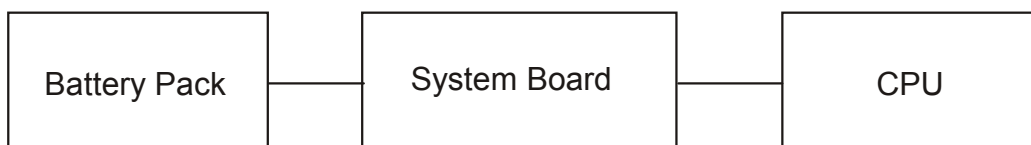

And if the connector is disconnected, connect it firmly to the system board and return to Procedure 1. If a foreign matter is found on Battery Pack, remove it and then return to Procedure 1. If there is still an error, perform Check 2.

**Check 2** Battery Pack may be faulty. Replace it with a new one following the steps described in Chapter 4. If Battery Pack replaced is still not functioning properly, perform Check 3.

**Check 3** System Board may be defective. Replace System Board with a new one following the steps described in Chapter 4.

## 2.22 HDMI Port

To determine if the computer's HDMI Port is functioning properly or malfunctions, perform following procedures. Start with Procedure 1 and continue with the other procedure as instruction below.

Procedure 1 Windows Application Test

Procedure 2 Connector Check and Replacement Check

### Procedure 1 Windows Application Test

The HDMI Port Connector is mounted on System Board. Connect an external monitor with HDMI interface to the computer's HDMI port, then power on the computer into Windows. The computer will automatically detect this external monitor through HDMI Port. If the external monitor appears to have a certain problem, go to Procedure 2. If an error is not located, HDMI Port is functioning properly.

### Procedure 2 Connector Check and Replacement Check

If HDMI Port on System Board malfunctions, there may be a bad connection between External Monitor and System Board. Or System Board or CPU might be faulty. Disassemble the computer following the steps described in Chapter 4 and perform the following checks:

**Check 1**      **Make sure External Monitor HDMI Cable has been firmly connected to HDMI Port on System Board. Also make sure HDMI Port on System Board is free of foreign matters.**

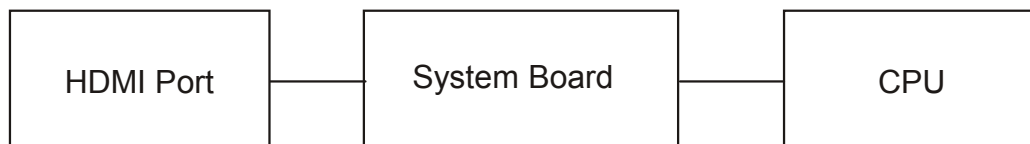

And if the connector is disconnected, connect it firmly to the system board and return to Procedure 1. If a foreign matter is found on HDMI Port on System Board, remove it and then return to Procedure 1. If the problem persists, perform Check 2.

**Check 2**      **System Board may be faulty. Replace it with a new one following the steps described in Chapter 4. If DHMI is still not functioning properly, perform Check 3.**

**Check 3**      **CPU may be defective. Disassemble the computer following the steps described in Chapter 4 and replace CPU with a new one.**

---

## **Chapter 3**

# **Diagnostic Programs**

---

---

## Chapter 3 Contents

---

3.1	General .....	1
3.2	Quick Start .....	3
3.2.1	Quick Test .....	3
3.2.2	Customization Test.....	3
3.2.3	Keyboard Layout test .....	7
3.2.4	Audio Play Test .....	8
3.2.5	Audio Record Test.....	9
3.2.6	DMI Read .....	9
3.2.7	DMI Write .....	10
3.2.8	System Information .....	11
3.2.9	View Logs .....	13
3.2.10	Exit to Free DOS .....	13
3.2.11	The Diagnostics Screen Explanation.....	13
3.3	Options.....	17
3.3.1	Overview .....	17
3.3.2	Batch Parameters Configuration .....	18
3.3.3	Item's Parameters Configuration.....	20
3.3.4	Load Batch Parameters.....	21
3.3.5	Save Batch Parameters .....	22
3.3.6	LOG Parameters Setting.....	23
3.3.7	Specify LOG Viewer.....	24
3.3.8	Display LOG File .....	24
3.3.9	LOG Viewer .....	25
3.3.10	LOG File Sample.....	26
3.4	Subtests .....	28
3.5	System Test.....	31
3.6	Memory Test.....	36
3.7	Storage .....	41
3.8	Video.....	45
3.9	Communication (COMM) .....	54

3.10	Peripheral .....	55
3.11	Error Codes and description.....	58
3.12	Quick Test Item List .....	i





## 3.1 General

This chapter explains the diagnostic programs which tests and diagnoses the functions of the hardware components of this computer. The diagnostic programs can be classified into two types: OPTION and DIAGNOSTIC TEST.

**NOTE 1:** *This Diagnostic supports Fez 10FT*

**NOTE 2:** *Before test must set SATA Controller Mode to “Compatibility” and Boot Mode to “CSM” in BIOS Advanced setting, when finished test reduction the settings.*

**NOTE 3:** *Before running a test, be sure to:*

- 1. Check that all the cables are connected securely.*
- 2. Exit the application that is currently running and close Windows.*

**NOTE 4:** *Please use Power on button to power on PC and Execute Service T&D rather than using quick boot. If by quick boot, since it doesn't re-flash memory data, sometimes, it will hang up.*

**NOTE 5:** *As the free DOS only support FAT16 Format Flash memory boot, Please use USB flash memory which size not more than 2G and format it to FAT format with label “FREEDOSUSB” before you make Service Diagnostic USB Flash Memory.*

The OPTION includes the following functions:

- Select All Items
- Test Select Items
- Edit Batch Parameters
- Load Batch Parameters
- Save Batch Parameters
- Log Parameters
- Specify Log Viewer
- Display Error Log File
- DOS Shell
- Exit to Free-DOS

The DIAGNOSTIC TEST Devices include the following tests:

- System Test
- Memory Test
- Storage Test
- Video Test
- Communication Test
- Peripheral Test
- Keyboard Layout Test

- Hot Key Test
- Audio Play Test
- Audio Record Test
- DMI Read
- DMI Write
- System Information

Before running the diagnostic programs, get the following tools prepared:

- A Service Diagnostic BOOT CD or USB Flash Memory
- A Formatted FLOPPY DISK
- A Test Media CD (A-BEX TEST CD-ROM TCDR-702)(for CD-ROM test)
- A Test Media DVD (Toshiba-EMI DVD-ROM TEST DISK TSD-1)
- An External Monitor (for DISPLAY test)
- A CD-ROM Driver (for CD-ROM test)
- Audio Line for audio record test
- A Data CD (for CD-ROM test)

The following chapters describe all the test details. The test items could be selected from the DIAGNOSTIC TEST menu.

**Note:**

When booting up the unit for the first time, the system will automatically select the location of the result log file. If a USB floppy drive is connected, and there is an unprotected floppy diskette with more than 50KB spare space in the drive, system will save all log files into the root directory of the diskette; otherwise, system will save all log files in the root directory of RAM disk.

## 3.2 Quick Start

When the system is booting from Service Diagnostic USB Flash Memory or CD, the following screen will be displayed:

```
Satellite L950/L955
Satellite S950/S955 Service Diagnostic
Version 1.00
-----
1. Quick Test
2. Customization Test
3. Keyboard Layout Test
4. Audio Play Test
5. Audio Record Test
6. DMI Read
7. DMI Write
8. System Information
9. View Logs
0. Exit to Free-DOS
-----
Enter Your Choice (0~9):
```

Please select a test item or select **0** to exit to Free-DOS:

### 3.2.1 Quick Test

When this item is selected, the system will run the configured test items and generate a test report automatically.

When the test is completed, a file named Quick.log would be saved in the defined location.

When Quick.log is being created, meanwhile, a file named quick.log has already existed, the system will automatically rename Quick.log to Quick.old for the backup purpose of the log file.

For the detail of test item, please refer to [Quick Test Item List](#).

### 3.2.2 Customization Test

When this item is selected, the system will run the diagnostic programs according to the procedures you defined. When the test is completed, a file named Custom.log will be saved in the defined location. Please see the following example-- Mouse test.

1. Use arrow key to select 'Mouse' item on 'Peripheral' in the menu, then press **Space** key to select it. (When it is being selected, there is a **X** marked in the [ ])

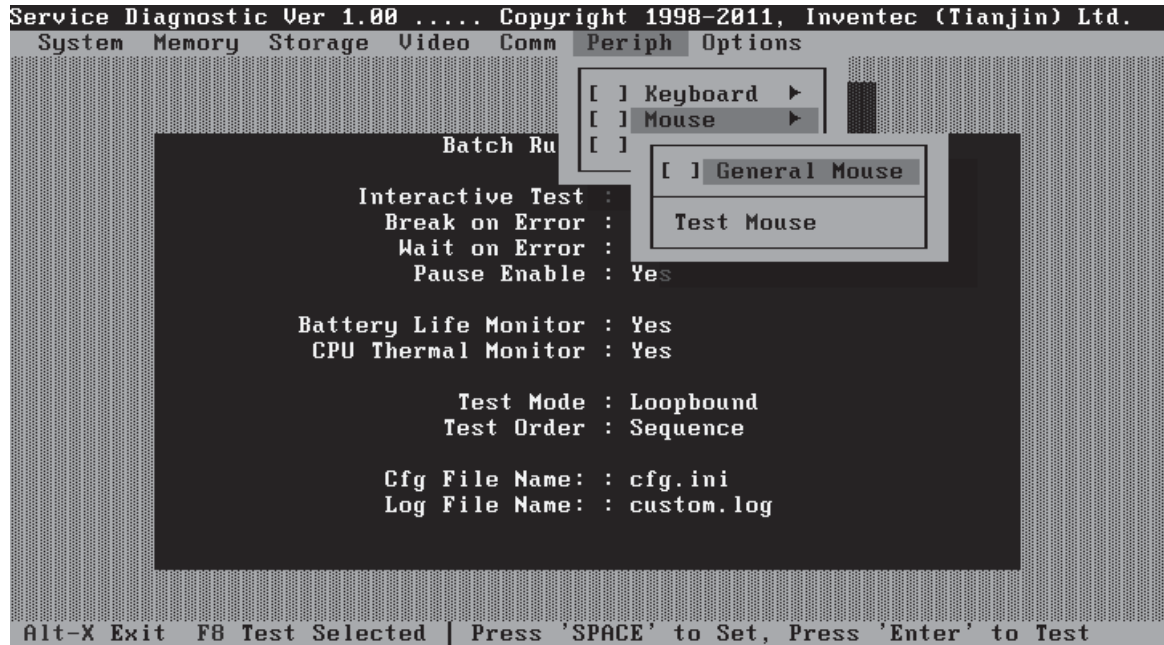

Select 'Test Mouse' or press **F8** to run the test. The prompt information would be displayed in the screen as below. This test item needs user to verify whether the mouse works normally.

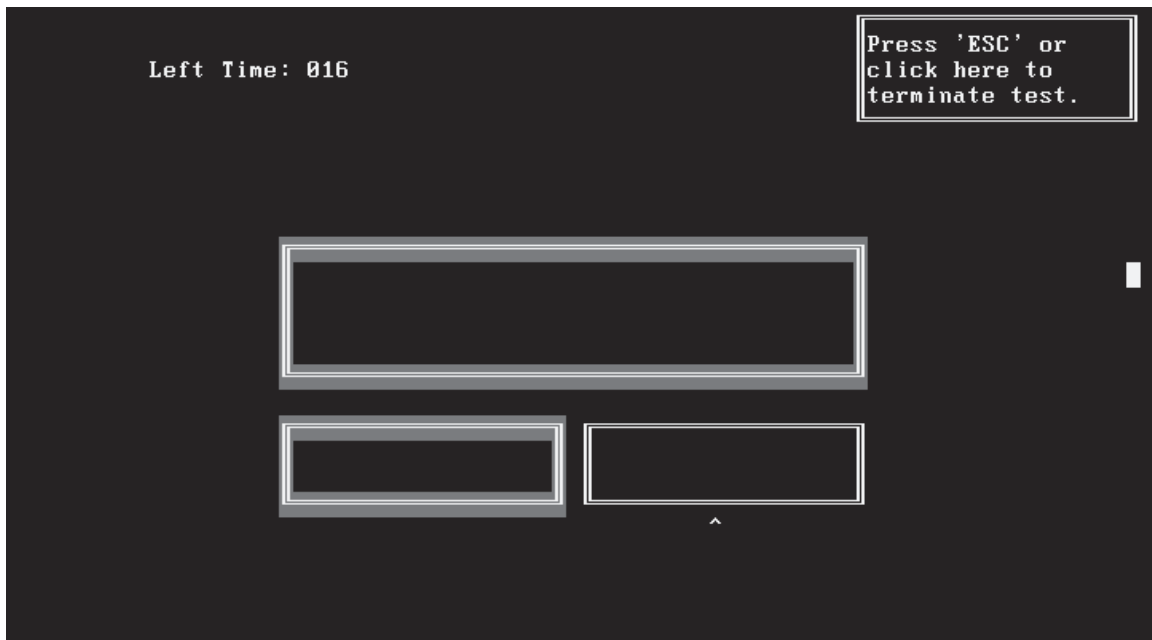

The test result will be displayed in the following screen:

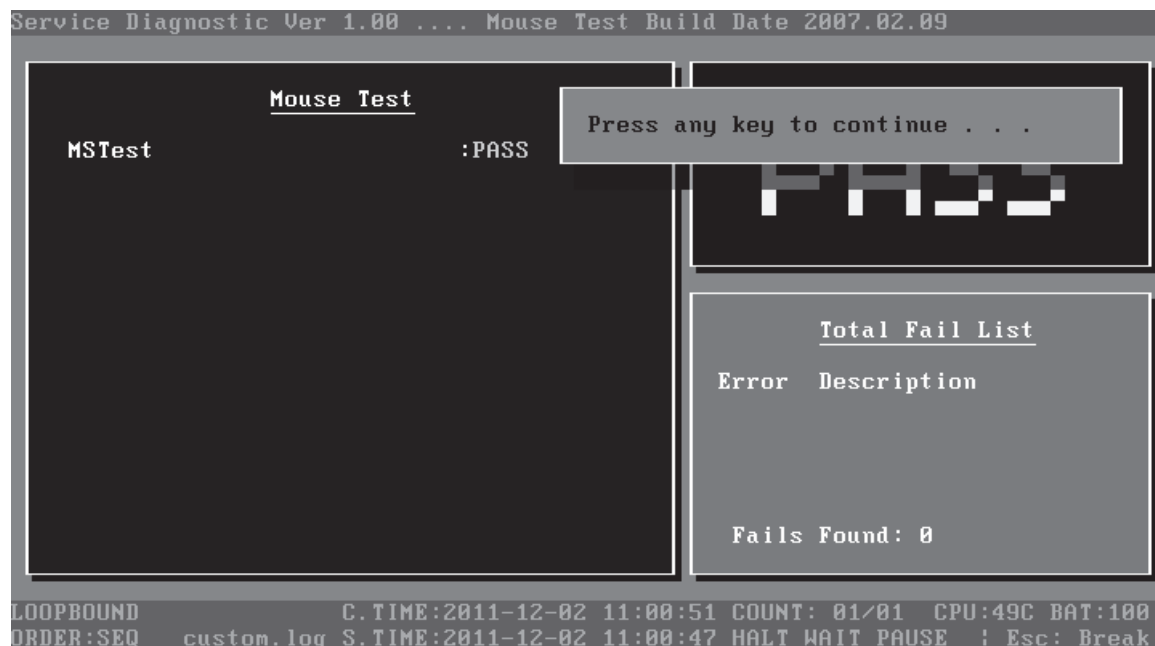

Here is another method to run the test: Highlight a test item by using arrow keys, then, press **Enter** to start. If there are parameters provided, user should set parameters in the parameter dialog window.

### CPU Speed Test (Step by Step):

1. Select test item:

Select **System—CPU—CPU Speed**, then, press the **Enter** key.

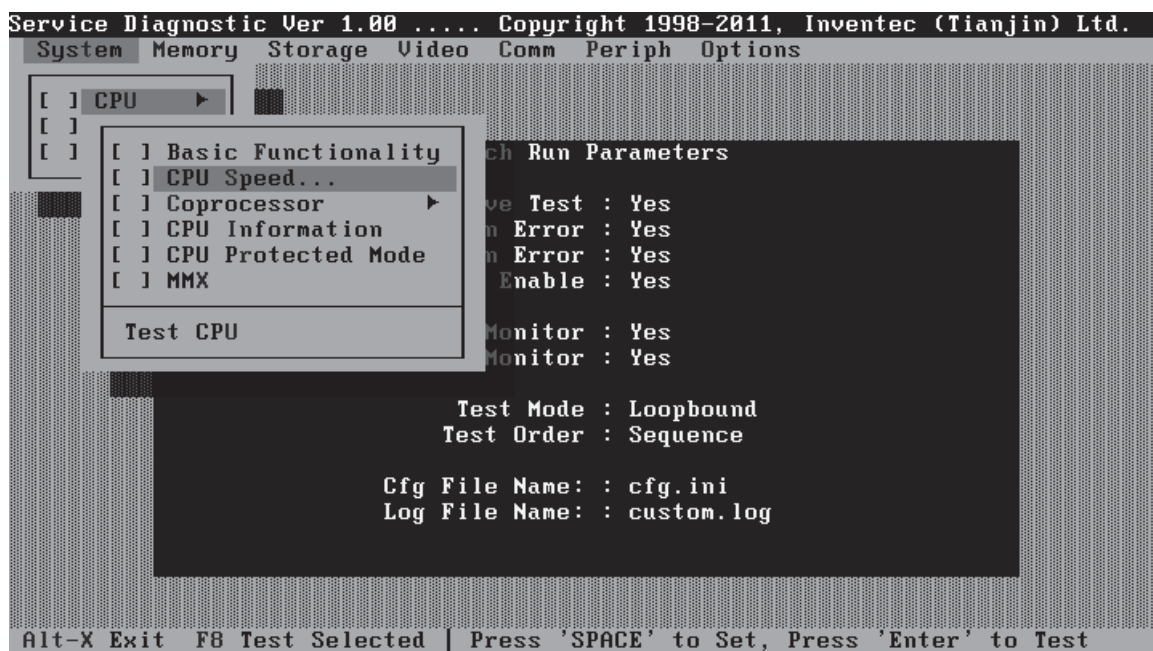

## 2. Parameters Setting

Choose the **OK** button after you set the proper parameters in the following window.

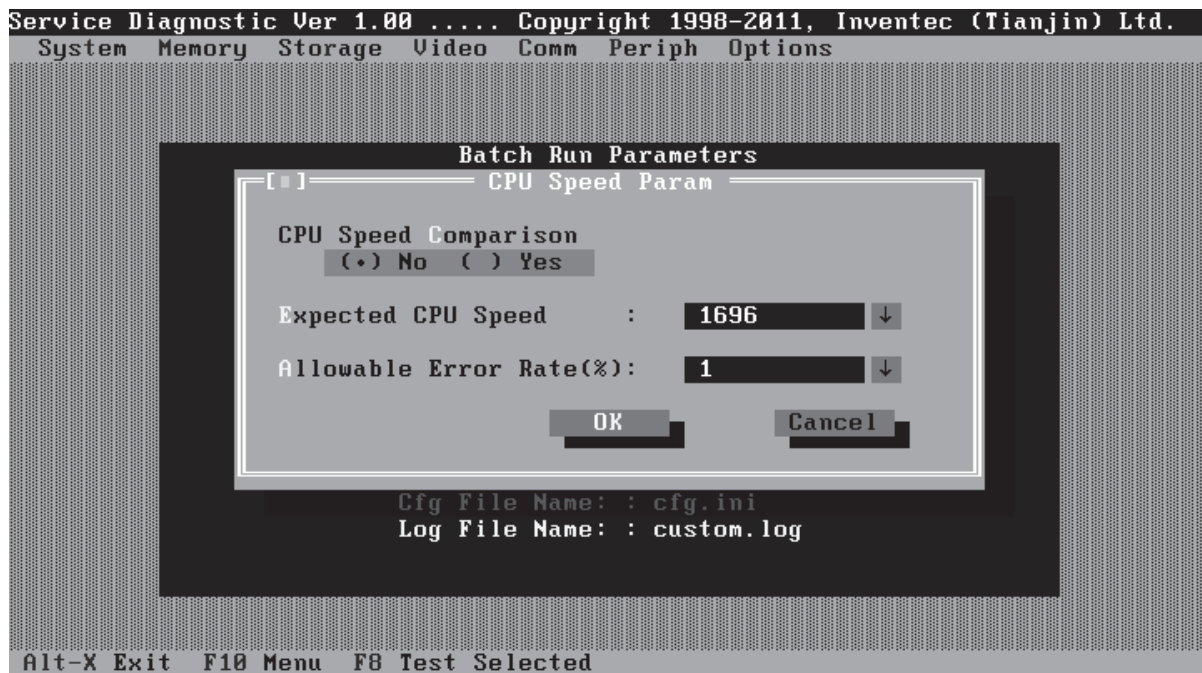

## 3. Test Result

System will automatically run and display the test result as follows:

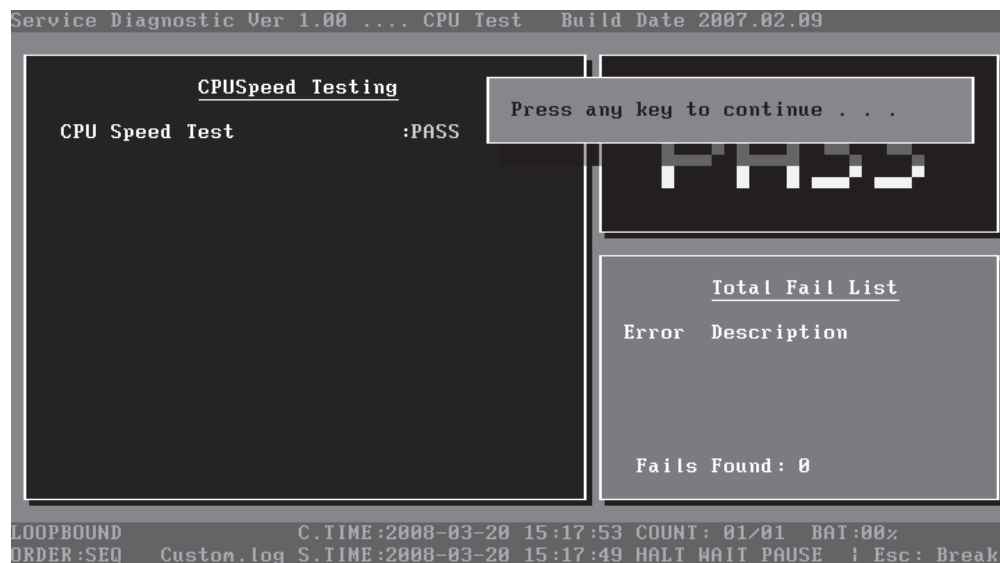

Following is the comparison report of the two testing methods mentioned above:

## 1) Configuration and Running

As to the method used in Mouse test, the user is required to select test items by pressing **Space** key and set the parameters artificially, (See [3.3.3 Item's Parameters Configuration](#)) Then press **F8** to start the test. User should configure each parameter in advance; otherwise the default parameters would be used. Using this method, user is allowed to select more than one test item at one time.

#### 2) Running the current test item

As to the method adopted in CPU Speed test, user should highlight the test item and press **Enter** to start testing. And the user has to setup the parameters every time before running the test. Using this method, only one test item would be tested at one time.

### 3.2.3 Keyboard Layout test

The test purpose is to check whether 30 kinds of keyboards run well during the test procedure. When users choose the item, the names of these countries will be displayed on the screen for user choice. User press any index of token in ASCII, and the program will test the kind of key map of the country.

```

Keyboard Layout Test
-----
1. US (United States)
2. JP (Japanese)
3. UK (United Kingdom)
4. KR (Korean)
5. TW (Traditional Chinese)
6. TH (Thai)
7. UE (US International)
8. HE (Herbrew)
9. DK (Danish)
A. SL (Swiss/Switzerland)
B. AR (Arabic)
C. CZ (Czech)
D. RU (Russian)
E. PT (Portuguese)
F. SK (Slovakian)
Ø. Exit
G. IT (Italian)
H. FR (French)
J. GK (Greek)
K. HU (Hungarian)
L. SP (Spanish)
M. TR (Turkish)
N. TF (Turkish F)
O. SW (Swedish)
P. BE (Belgian)
Q. YU (Yugoslavian)
R. NO (Norwegian)
S. N5 (Scandinavian)
T. CM (Canadian Multinational)
U. QB (Canadian Bilingual)
-----
Detecting machine type, itcdiag is launching...

```

The test screen would be shown as below:

```

Left Time: 088
oneKeyMsg = 0xff

Esc F1 F2 F3 F4 F5 F6 F7 F8 F9 F10 F11 F12 INS DEL
~ 1 2 3 4 5 6 7 8 9 0 - = Back Home END PgUp PgDn
Tab Q W E R T Y U I O P { } | Num / * -
Caps A S D F G H J K L : ' enter 7 8 9
Shift Z X C V B N M , . / Shift 4 5 6
Ctrl Fn Win Alt Space Alt App Ctrl Up 1 2 3
< Dn > 0 . Enter

```

Press Fn+PGDN to test Fn.  
Please press the key one by one and 'E' 'N' 'D' to skip this test.

It requires user to press the key and check whether the key in the screen changes color or not. User can terminate test by typing 'END'.

When the user has checked all the keys and all the keys in the screen have changed color, the diagnostics program would automatically end the test and report the pass Information.

If keyboard test fails, program will terminate the test and report the fail information when it is time to timeout.

The test will end when all keys are pressed or test time is out after 90 seconds.

### 3.2.4 Audio Play Test

Check whether the system could playback audio normally. When the test is completed, a file named Audio\_p.log will be saved in the defined location.



```

HD Codec DOS Test Program Version:3.81

Play a wave file (48k sampling rate/16-bits stereo file)
You must hear some music. Yes/No ?
Press 'Y' to stop playing(If the function is passed)
Press 'N' key (If the function is failed)
1.Line_Out Left Channel Test
2.Line_Out Right Channel Test
Playing 44K wave file
Playing 48K wave file
Playing properly finish !
Test DAC=2 to ADC=8 loopback.
Pass DAC=2 ADC=8 Recording Test!!
Test DAC=3 to ADC=9 loopback.
Pass DAC=3 ADC=9 Recording Test!!
Testing JD!
Pass Widge=14 Test!
Pass Widge=21 Test!
Pass Widge=1a Test!
Pass Widge=1b Test!

Copyright(C) 2011, Realtek Semiconductor CO. Ltd

```

### 3.2.5 Audio Record Test

Check whether the system could record the sound normally. If there is no error during the whole test, Pass; otherwise, Fail. When the test is completed, a file named Audio\_r.log will be saved in the defined location.

```

HD Codec DOS Test Program Version:3.81

Test DAC=2 to ADC=8 loopback.
Pass DAC=2 ADC=8 Recording Test!!
Test DAC=3 to ADC=9 loopback.
Pass DAC=3 ADC=9 Recording Test!!
Test OUTPUT=21 INPORT=18 Playback/Recording:
Pass OUTPUT=21 INPORT=18 Recording Test!!
OUTPUT=21 INPORT=18 L/R testing:
Pass INPORT=18 L/R Channel Short Test!
Testing JD!
Pass Widge=14 Test!
Pass Widge=21 Test!
Pass Widge=1a Test!
Pass Widge=1b Test!

Copyright(C) 2011, Realtek Semiconductor CO. Ltd

```

**NOTE 1:** This test needs an audio loopback cable.

### 3.2.6 DMI Read

Read the information from the system's SMBIOS and display it in the screen as follows:

```

DMI Information                                     Version 1.00
-----
Manufacture      : TOSHIBA
Product Name    : Satellite L950
Version         : PSKGGC-CSSKU3
Serial Number   : 8C051517Q
UUID           : 2504ACE0DBC111E196AB00266C2950AC
OEM Part Number : PSKGGC-CSSKU3
OEM SW Number  : TI309269X0A

-----
Press any key to exit...

```

User can press any key to exit the program.

### 3.2.7 DMI Write

In addition to reading the DMI information, **DMI Write** also permits attributes editing and updating: Manufacture, Product Name, Version, Serial Number, and OEM Part Number, etc. The following screen will be displayed:

```

DMI Information - Modify                             Version 1.00
-----
Manufacture      : TOSHIBA
                  : TOSHIBA
Product Name    : Satellite L950
                  : Satellite L950
Version         : PSKGGC-CSSKU3
                  : PSKGGC-CSSKU3
Serial Number   : 8C051517Q
                  : 8C051517Q
UUID           : 2504ACE0DBC111E196AB00266C2950AC
OEM Part Number : PSKGGC-CSSKU3
                  : PSKGGC-CSSKU3
OEM SW Number  : TI309269X0A
                  : TI309269X0A

-----
F2:Confirm the change  F4:Ignore the change  ESC: Exit
Press ENTER key to complete an item's modification

```

In this screen, there are two lines which attribute could be edited and updated. The 1<sup>st</sup> line (the font in yellow with blue background) shows the attribute's value that is read from the current system and the 2<sup>nd</sup> line (the font in red with turquoise background) shows the same value as that in the 1<sup>st</sup> line before user's editing. User can modify the attribute's value in the 2<sup>nd</sup> line and press **Enter** to confirm the current edition and continue editing the next attribute.

During the editing, user could press **F2** to confirm the DMI attribute update or press **F4** to ignore the modification. Press **ESC** to exit the program of DMI Write.

The confirmation screen is as below:

```
DMI Information - Check                                     Version 1.00
-----
Manufacture       : TOSHIBA
Product Name     : Satellite L950
Version          : PSKGGC-CSSKU3
Serial Number    : 8C051517Q
UUID             :
OEM Part Number  : PSKGGC-CSSKU3
OEM SW Number    : T1309269X0A

-----
F2: Save the change   F4: Edit again
Please restart after updating DMI information
```

The attributes that have been modified would be marked in red; otherwise in yellow. User could press **F2** to save the changes, or press **F4** to ignore and exit the current program.

### 3.2.8 System Information

This function is used to read the system information. When the test is completed, a file named System.log will be saved in the defined location. During the reading process, the following screen will be displayed to indicate that the progress is in detection:



On the left column of the above screen, the detected hardware components are listed. The corresponding information of the detected hardware components is displayed on the right of the screen. It displays the current running status information of the check program. The name of the program is marked on the top of the screen. At the bottom, the function keys are listed for user operation. During the detection, keyboard operation is invalid.

When the detection is finished, the hardware components information will be displayed as follows:

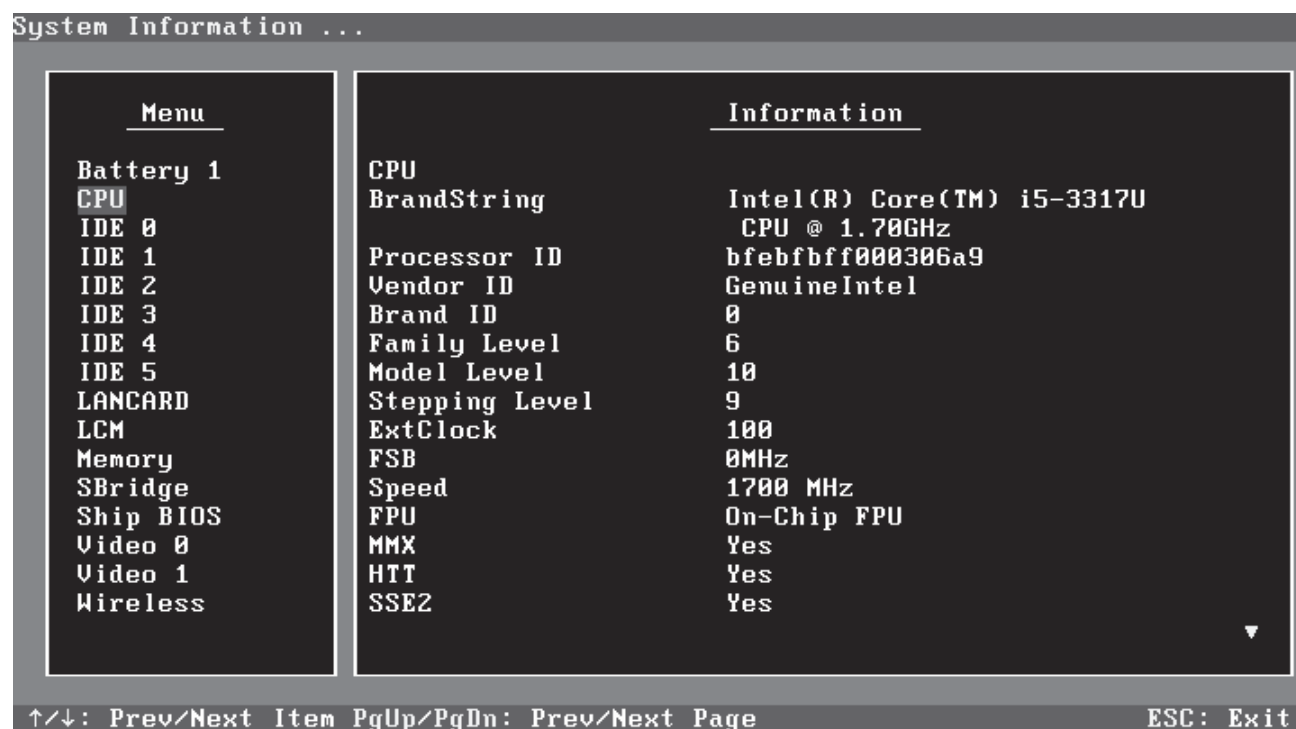

User can use function keys listed on the bottom of the screen to display the configuration of the component or exit the current program. On the left column, the components information is listed and user can use arrow keys or **PgUp/PgDn** to view the list and highlight the chosen component. On the right column, the configuration information of the highlighted component is listed. Press **ESC** to exit this program.

### 3.2.9 View Logs

User can enter one choice to view a log file in the screen as follows.

```
Select a Log to view:
-----
1. Quick Test Log
2. Customization Test Log
3. Keyboard Layout Test Log
4. Audio Play Test Log
5. Audio Record Test Log
6. System Information
0. Exit to Main Menu
-----
Enter Your Choice (0--6):
```

### 3.2.10 Exit to Free DOS

Select this item to exit to Free DOS.

### 3.2.11 The Diagnostics Screen Explanation

Below is an example of running a test item. It includes the following parts: Diagnostics Windows, Test Status Area, Progress Bar, Error List, Test Item's Title, Status Bar and Message Box.

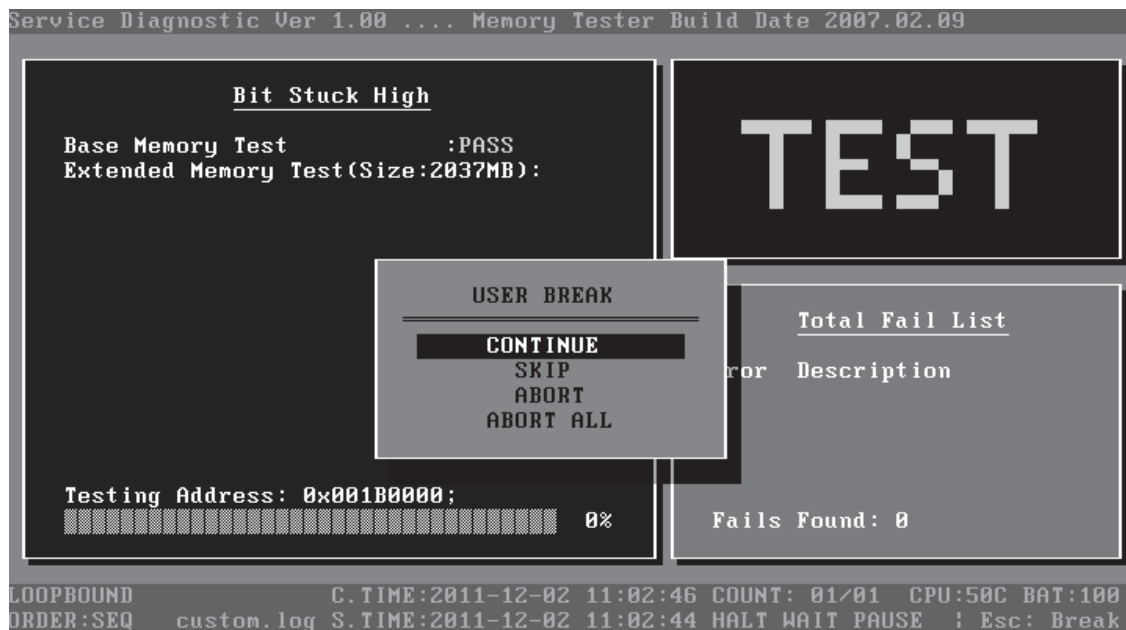

### 1. Diagnostics Windows

When a test item is running, a Diagnostics Windows is displayed in full screen. It consists of the following parts: Title Bar, Test Running Status and Report Panel, Status Bar. There would prompt a message box called USER BREAK in the central of the window whether user press **ESC** to interrupt the test.

### 2. Test Running Status and Report Panel

Test Running Status and Report Panel are located on the middle of Diagnostics Windows.

- ◆ Test item name, test process and test result are displayed in the left;
- ◆ Test status and result are displayed in the upper right corner of the screen. It displays the test status of the current test item – TEST (in testing), PASS (test finished and its result is passed), FAIL (test finished and its result is failed) and SKIP (test skipped).
- ◆ The error list of each test module is displayed at the lower right corner of the screen. It would display the total error quantity found in the test, the most recent five error codes and description would be shown here. Detailed error report could be viewed with Logview.exe.
- ◆ When pressing **ESC** key during the test process, a User Break Windows will be popped up for the user to select.

### 3. USER BREAK

Pressing **ESC** key to interrupt the test, **USER BREAK** message box would be prompted out in the central of Diagnostics Window for the user to select the following actions:

- ◆ **CONTINUE**---- Continue the test;
- ◆ **SKIP**---- Stop the sub-item of current test item to go to the next item's test;
- ◆ **ABORT**----Stop the current test item to test the next module.
- ◆ **ABORT ALL**---- Stop all the selected test items. User could use the hot key **Ctrl+D** to achieve the same operation. When the user calls **ABORT ALL**, the following message box will prompt for his selecting.



#### 4. Title Bar:

Title Bar located at the top of the window, it includes information as follows:

- ◆ **Program Name and Its Version:** Service Diagnostic Ver1.10;
- ◆ **Test Module Name:** Label the name and version of the test module. For example, in the above screen, the name of the test module is 'Memory Tester Build Date 2007.02. 09'.
- ◆ **Status Bar:** Located at the bottom of the screen as follows:

```
LOOPBOUND          C.TIME:2008-02-16 00:42:40 COUNT: 01/01 CPU:56C BAT:46%
ORDER:SEQ   Custom.log S.TIME:2008-02-16 00:42:28 HALT WAIT PAUSE ; Esc: Break
```

The status bar is used to indicate the current script setting and test status. It consists of two lines that includes the information as follows:

- ◆ **Test Mode:** TIMEBOUND or LOOPBOUND, e.g. LOOPBOUND in the above screen;
- ◆ **Script File Name:** Script file name, e.g. 'Custom.INI' in the above screen;
- ◆ **Current Time(C. TIME):** Current system time, e.g. 'C.TIME:2008-02-16 00:42:40' in the above screen;
- ◆ **Test Time Remaining (LEFT):** In TIMEBOUND mode, it would display the remaining test time at the same location as Current TIME (C. TIME) in the above screen;
- ◆ **Current Loop Count:** In LOOPBOUND mode, it will display the total LOOP number planning to execute and the current LOOP number have been finished, e.g. 'COUNT: 01/01' in the above screen;

- ◆ **CPU Temperature:** Detect the temperature in the current CPU, e.g. 'CPU: 56C' in the above screen;
- ◆ **Remaining Battery Capacity:** Remaining Battery Capacity detected in the current Battery, e.g. 'BAT: 46%';
- ◆ **Test Order:** Define the test sequence. There is two sequence modes: Sequential Test Mode and Random Test Mode. The default mode is Sequential Test Mode, it would displays 'ORDER: SEQ' as in the above screen;
- ◆ **LOG File Name:** Display the file name of the test log, e.g. Custom.Log in the above screen;
- ◆ **Start Test Time (S.TIME):** Display the test start time for the current test item or the test script, e.g. 'S.TIME: 2008-02-16 00:42:28' in the above screen;
- ◆ **Break On Error:** Display 'HALT' as shown in the above screen when 'Break On Error' is enabled;
- ◆ **Wait On Error:** Display 'WAIT' as shown in the above screen when 'Wait On Error' is enabled;
- ◆ **Pause Enable:** Display 'PAUSE' when "Pause Enable" is enabled;
- ◆ **Manual Interrupt Method:** Display 'Esc: Break' to tell the user how to manually interrupt the test process.



## 3.3 Options

### 3.3.1 Overview

In Service Diagnostics, with the **Options** menu user can configure the batch parameters, test item's parameters and those parameters created by the LOG file.

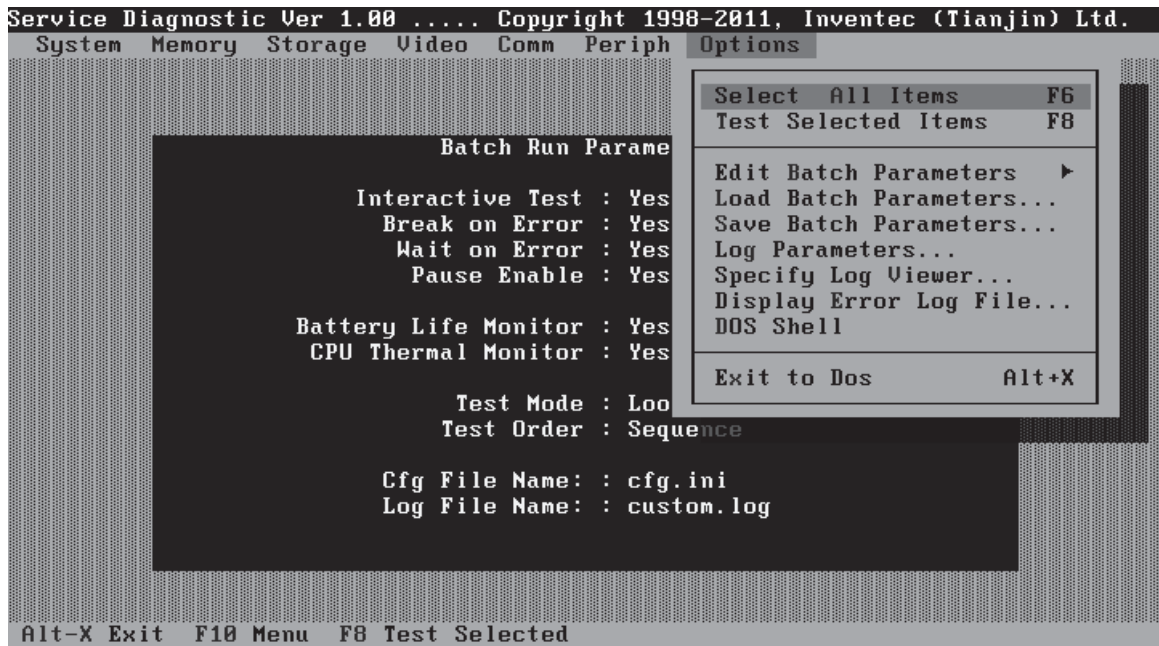

#### Options Menu Notes:

- Select All/None Items

Switch between selecting all test items and selecting none. The hot key is **F6**.

- Test Selected Items

Execute all selected test items in this editor. The hot key is **F8**.

If “Interactive” option in batch parameters has not been selected, a warning message would be shown as below:

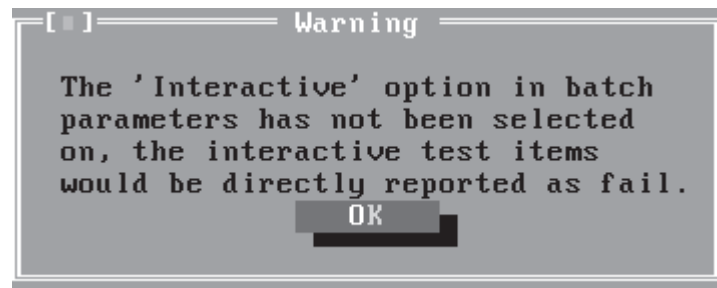

- Edit Batch Parameters

Configure batch parameters and all the test item's parameters.

- Load Batch Parameters

Upload all the test items and the parameters to the \*.ini file.

- Save Batch Parameters

Save all the parameters and the test items that are configured in the editor to a specified file.

- Log Parameters

Configure LOG parameters.

- Specify LOG Viewer

Specify the viewer for the LOG file.

- Display Error Log File

Load the LOG file viewer specified in the Specify Log Viewer to view the LOG file.

- DOS Shell

Enter the DOS Shell and execute the DOS programs. You can also exit to the Service Diagnostics Editor by the command of **EXIT**.

- Exit to DOS

Exit the Service Diagnostics Editor and back to DOS.

### 3.3.2 Batch Parameters Configuration

The batch parameters configuration screen can be accessed through Service Diagnostics/OPTIONS -> EDIT BATCH PARAMETERS -> BATCH PARAMETERS:

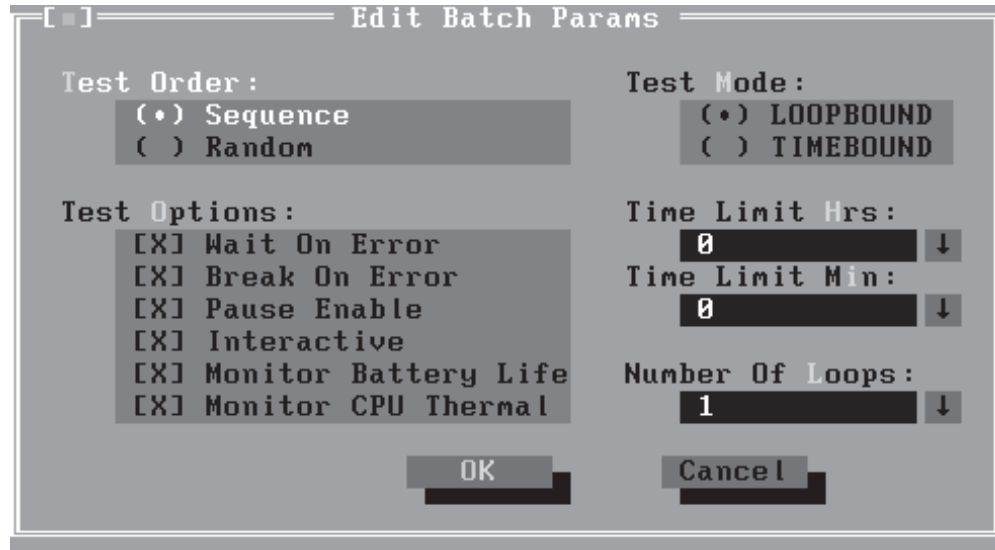

- **Test Order**

Specify the order of the test items. Choose 'Sequence' to adopt the sequential mode; choose 'Random' to run the test items in random sequence.

- **Test Options**

Choose one of the following options:

- ✓ **Wait On Error**

Wait for further confirmation while an error occurs.

- ✓ **Break On Error**

Stop the test when a test item fails.

- ✓ **Pause Enable**

Pause at the end of each test items and wait for the user to response with the test items that requires the user to assist the test processes, such as the keystroke test.

- ✓ **Interactive**

If the item is enabled during the test, the test items that need user to response can run normally, such as Mouse test; If it is disabled, those test items will report FAIL.

When the option here is enabled, it would affect all the test items while the same option in “Item Parameters Configuration” only affect that test item.

- ✓ **Monitor Battery Life**

Monitor the remaining battery capacity (percent).

✓ **Monitor CPU Thermal**

Monitor the CPU temperature.

- **Test Mode**

✓ **LOOPBOUND**

The chosen test items will run repeatedly according to the times specified in the 'Number of Loops'.

✓ **TIMEBOUND**

The chosen test items will run for an extent time specified in 'Time Limit Hrs' and 'Time Limit Min'.

- **Time Limit Hrs**

Specify the hours whether 'TIMEBOUND' is chosen under the batch mode.

- **Time Limit Min**

Specify the minutes whether 'TIMEBOUND' is chosen under the batch mode.

- **Number Of Loops**

Specify the repeating times when 'Loop Bound' is chosen under the batch mode.

### 3.3.3 Item's Parameters Configuration

The test items' parameters configuration screen can be accessed through Service Diagnostics/Options -> Edit Batch Parameters -> Item's Parameters-> System->CPU-> Basic Functionality:

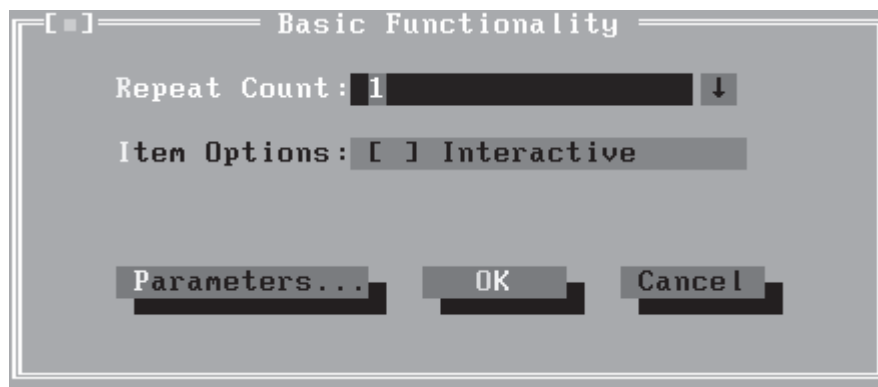

- **Repeat count**

Repeat times of the test item.

- **Interactive**

If the item is enabled during the test, the test items that need user to response can run normally, such as PS2 Mouse test; If it is disabled, those test items will report FAIL.

Whether the option here is enabled, it only affects the current test item.

- **Parameters**

For the test items with specific parameters, this option will call the related configuration screens. Otherwise, the program will show the following dialogue window:



Parameters for the specific test items:

Some test items (Memory, HDD, e g...) have their individual parameters, which can be configured in their parameters setting window.

### 3.3.4 Load Batch Parameters

Batch parameter is saved in the script file whose extension name is INI (\*.INI). Below is the screen shot of "Load Batch Parameters".

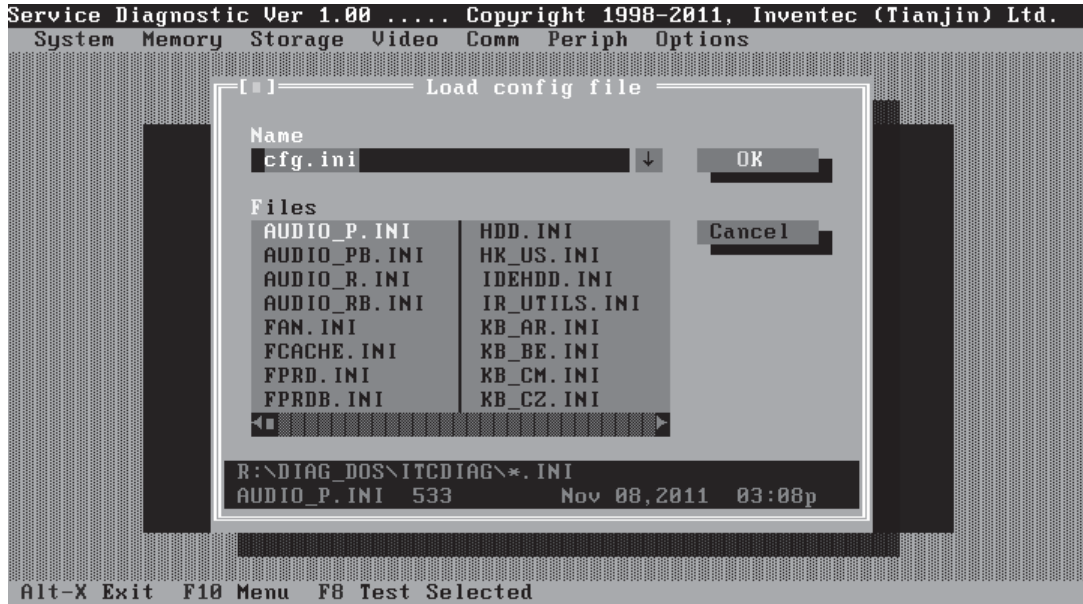

In this window, you can specify the .INI files that you wanted to be edited or modified.

### 3.3.5 Save Batch Parameters

Here you can save the edited or modified content to the batch parameters files.

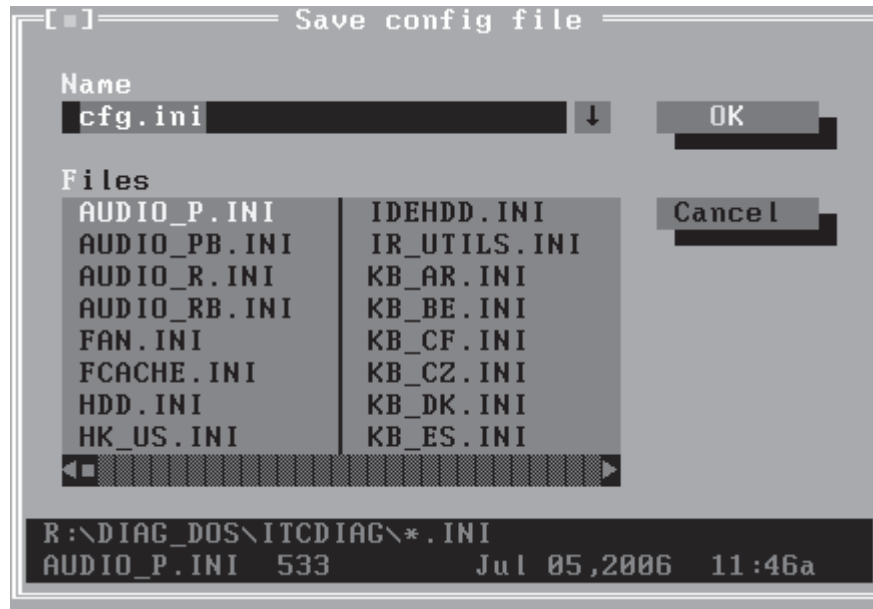

### 3.3.6 LOG Parameters Setting

You can access the Log Parameters screen through Service Diagnostics\Options - Generate Report.

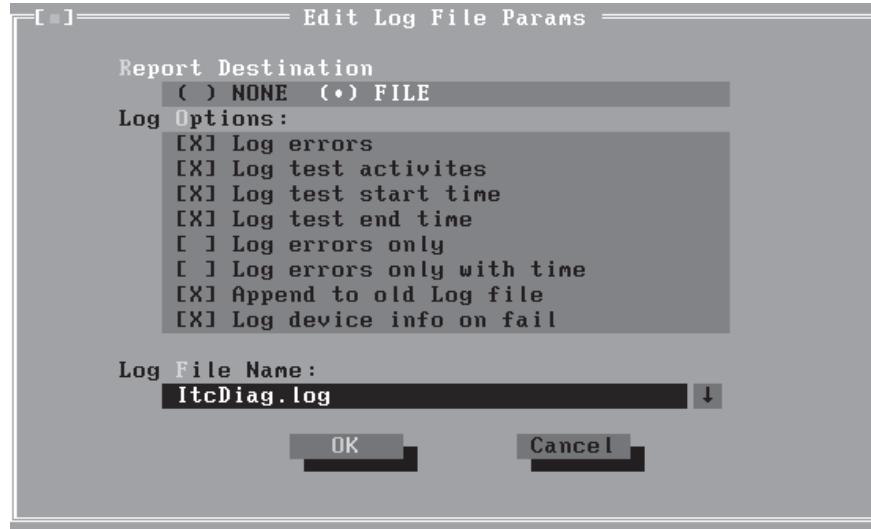

- **Report Destination**

If selecting 'NONE', no log file will be generated; if selecting 'FILE', a log file with the name specified in 'Log File Name' will be generated.

- **Log Options**

- ✓ **Log Errors**

If selecting this parameter, errors will be recorded when the test fails.

- ✓ **Log Test Activities**

If selecting this parameter, the subtest results will be recorded.

- ✓ **Log Test Start Time**

If selecting this parameter, the start time of the test will be recorded.

- ✓ **Log Test End Time**

If selecting this parameter, the end time of the test will be recorded.

- ✓ **Log Errors Only**

If selecting this parameter, errors will be recorded only when the test fails.

- ✓ **Log Errors Only with Time**

If selecting this parameter, errors and time will be recorded only when the test fails.

✓ **Append to Old Log File**

If selecting this parameter, the new log will be added to the old one.

✓ **Log Device Info on Fail**

If selecting this parameter, details of the failed test will be recorded.

• **Log file Name**

Specify the Log file name. You can input the detail path of the file. System will show the detail path of the file.

### 3.3.7 Specify LOG Viewer

You can specify the Log file viewer in the Specify Log Viewer screen.

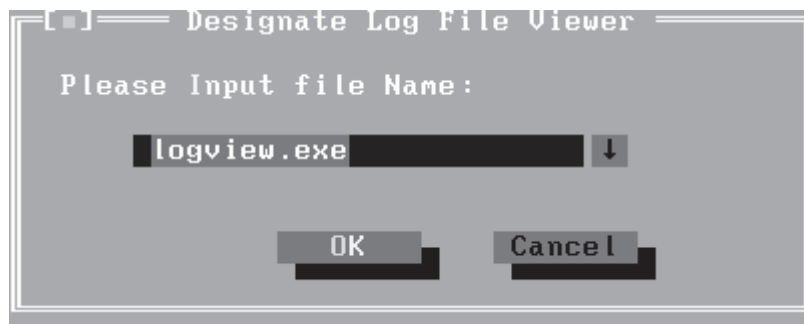

The default viewing program of Service Diagnostics is **LogView.exe**.

### 3.3.8 Display LOG File

You can specify the Log file for viewing in the Display Error Log File screen.



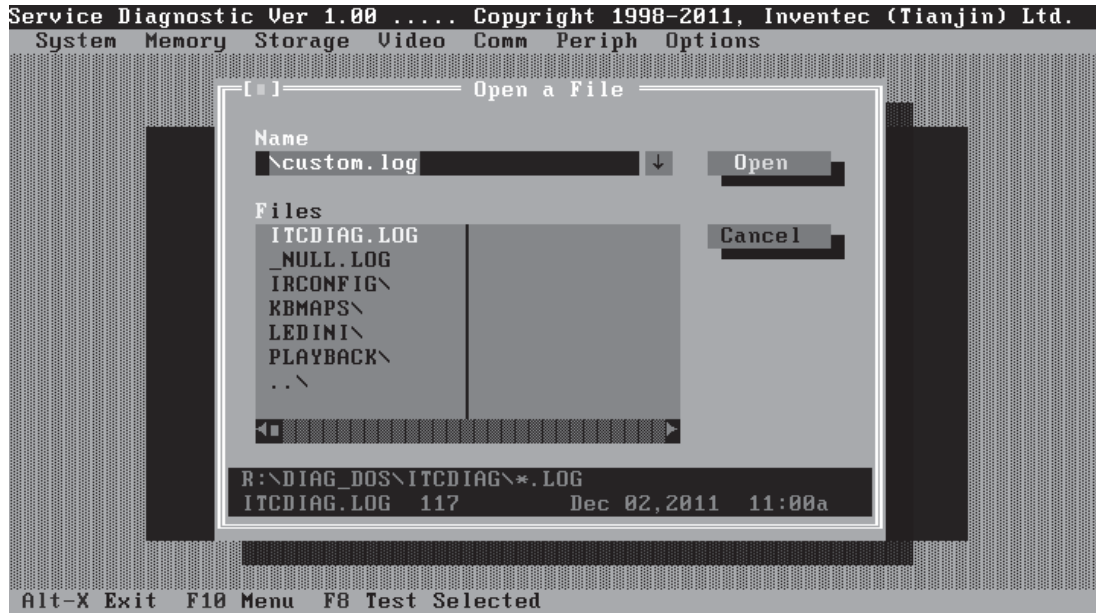

In this screen, you can specify a Log file and view it with the viewer designated in Specify LOG Viewer.

### 3.3.9 LOG Viewer

Service Diagnostic Log viewer:



- ↑, ↓

Scroll a line backward or forward on the screen.

- Page Up, Page Down

Scroll a page backward or forward on the screen.

- **Esc**

Exit the Log viewer.

- **F1**

Display the Help information about the Log viewer operations and the functional keys.

- **Ctrl+Home**

Go to the start of the log file.

- **Ctrl+End**

Go to the end of the log file.

- **Ctrl+F3**

Prompt the search dialogue for the user to input the string to be looked for and specify the searching method.

- **F3**

Find the next corresponding strings given.

### 3.3.10 LOG File Sample

Log file is a test result file, which records the following information: Test module name, Test item name, Start/End time and the test result (including PASS, FAIL, SKIP and ABORT). When a failure is found, both the error code and the error information were recorded.

In the Log file, we use **Test Items** as the test item name, which could not be modified in the whole time. And we use the **Internal Name** as name in the program's UI, which corresponds to the test item name and could be modified according to the user's favorite.

The following section is a sample of log file:

*DIAG REPORT*

*<Module Name>: Service Diagnostic Ver 1.00 ... Memory Tester Build Date 2006.01.10*

*[Walk High]*

*Begin Time: Wed Jul 05 10:45:36 2006*

Base Memory Test : PASS  
Extended Memory Test : PASS  
End Time: Wed Jul 05 10:47:51 2006

<Module Name>: Service Diagnostic Ver 1.00 ... Mouse Test Build Date 2006.01.10

[MSTPad]  
Begin Time: Wed Jul 05 10:48:54 2006

Touch Pad Test : FAIL  
ITEM TEST FAIL  
Function ID :502  
Error Code :50202  
Error Message :Touch Pad Test Fail  
End Time: Wed Jul 05 10:49:16 2006

## 3.4 Subtests

Test Group	Sub Item ID	Subtest	Test ID	Test items	Internal Name	
System	01	CPU	01	Basic Functionality Test	[CPUBasicFun]	
			02	CPU Speed	[CPUSpeed]	
			03	Coprocessor NPU Basic Functions	Coprocessor [NPUFun]	
			04	CPU Information	[CPUInformation]	
			05	CPU Protected Mode	[Protect]	
			06	MMX	[MMX]	
	02	Board	01	DMA Controller	[DMACtrl]	
			02	Interval Timer	[Timer]	
			03	Clock / Calendar	[RealClock]	
			04	PCI System	[PCI]	
			05	Plug and Play	[PnP]	
03	FAN	01	CPU Fan Speed Test	[FANSpeed]		
Memory	01	BIOS ROM			[BIOSROM]	
			02	Pattern	01	Bit Stuck High Test
				02	Bit Stuck Low Test	[BSLow]
				03	Checker Board Test	[ChkBd]
				04	CAS Line Test	[CASLine]
				05	Incremental Test	[Incrment]
				06	Decremental Test	[Decrment]
				07	Incremental Decremental Test	[Idcrment]
	03	Extended Pattern	01	Write/Read Cycle Test	[XWRCycle]	
			02	Read Cycle Test	[XRCycle]	
		04	Walking 1's Test		[WalkHigh]	
	05	Walking 0's Test		[WalkLow]		
	06	Memory Address		[Address]		
	07	Refresh Test		[Refresh]		
	08	Cache Memory		[CacheOne]		
	09	Random Memory	01	Randomize Test	[Random]	
			02	Random Increment Read/Write	[RandIncr]	
	10	Data Bus Test		[DataBus]		
	11	Bus Noise		[BusNoise]		

	12	Memory Speed Test			[MemSpeed]
Storage	01	HDD	01	Sequential/Random R/W	[SeqRdRW1]
			02	Sequential/Random Seek	[Seek1]
			03	Performance	[Perform1]
			04	Controller Check	[Controller1]
			05	Diagnostic Read/Write	[DiagRW1]
			06	SMART Test	[SMART1]
Video	01	Text Mode	01	Character Test	[CharTest]
			02	Text Attribute	[Attribut]
			03	Text Page Selection	[PageSel]
			04	Text Color	[Color]
			05	80*25 Text Mode	[Text Mode]
	02	640*480 VGA Mode			[VGAMode]
	03	VESA Video Modes	01	640X480 Video Modes VESA 640x480x256 Mode VESA 640x480x32K Mode VESA 640x480x64K Mode VESA 640x480x16K Mode VESA 640x480x32bit Mode	[V640480_15] [V640480_16] [V640480_24] [V640480_32]
			02	800X600 Video Modes VESA 800x600x256 Mode VESA 800x600x64K Mode VESA 800x600x32K Mode VESA 800x600x16K Mode VESA 800x600x32bit Mode	[V800600_15] [V800600_16] [V800600_24] [V800600_32]
	04	VESA Video Memory			[VESAMEM]
	05	AGP Test			[AGP]
	06	LCD Panel Test			[LCDPanel]
	07	Register Test			[Register]
	08	Color Purity Test			[ColPurity]
	09	Direct Color Test			[DirectColor]
	10	DAC/Palette Address			[DACPalAddr]
	11	Bitblt Engine Test			[Bitblt]
COMM	01	LAN Card	01	Device ID Detection	[DeviceID]
			02	Vendor ID Detection	[VendorID]
			03	Mac Address Detection	[MAC Address]

Peripheral	01	Keyboard	01	Keyboard Data Line	[KBDataLn]
			02	Keyboard Clock Line	[KBClokLn]
	02	Mouse	01	TouchPad	[MSTpad]
	03	Led	01	Device Led	[KBLED]

### 3.5 System Test

Move arrow keys and press the **Space** key to select CPU test item from Service Diagnostic menu, then highlight **CPU** and press the **Enter** to run this test item.

#### Subtest 01 CPU

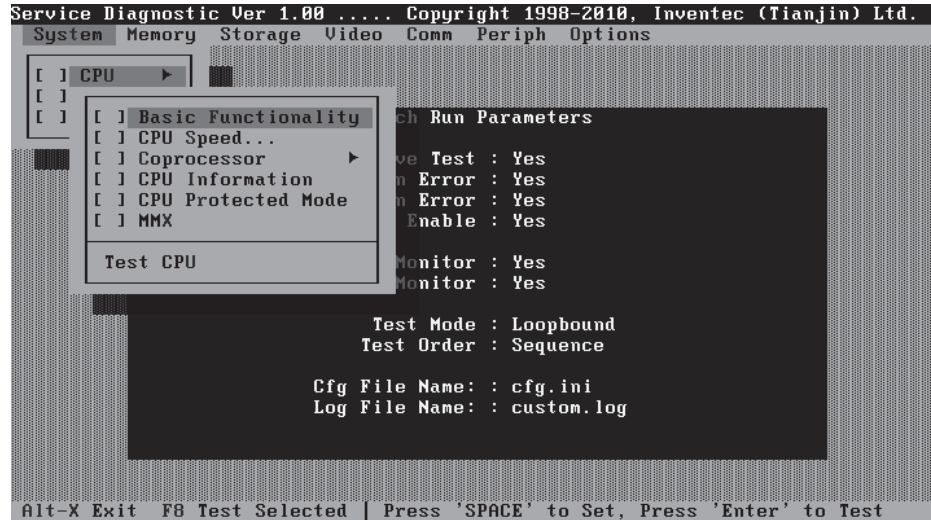

#### 1. Basic Functionality Test

This test item is to check whether the CPU works normally through math and logic calculation, which means verifying the general registers, math registers and logic registers.

#### 2. CPU Speed

This test item is to detect the work frequency of the current CPU. User should change the parameters setting in the following window before the test:

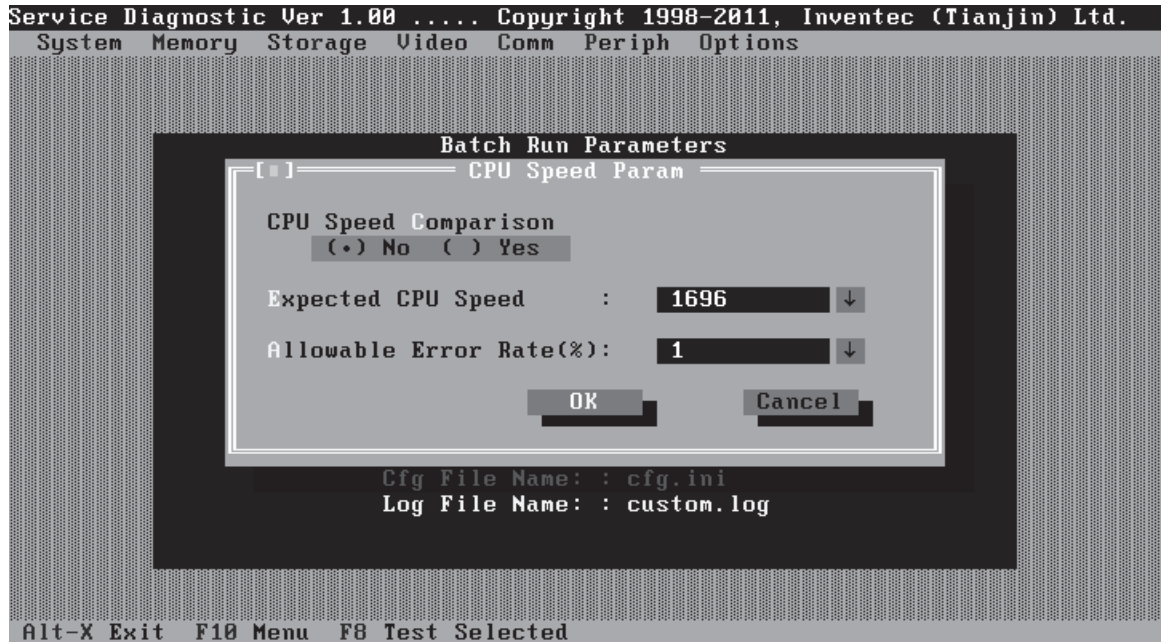

**CPU Speed Comparison**--Whether you want to make a comparison of the CPU speed with the value set in 'Expected CPU Speed', you should choose 'Yes'; otherwise, 'No'.

**Expected CPU Speed**--Specify the expected CPU Speed value you want for further comparison.

**Allowable Error Rate**-- Specify the Allowable Error Rate value you want for further comparison.

### 3. Coprocessor

#### ✓ NPU Basic Functions Test

This test item is to check whether the precision of the numeric processor in the float calculation is up to the IEEE standards.

### 4. CPU Information

This test item is used for getting & showing CPU Information. It will be displayed as follows:



```

Service Diagnostic Ver 1.00 ... CPU Test   Build Date 2007.02.09

  CPUInformation Testing
  CPU Information      :
  Standard Speed = 1700MHz
  Current Speed = 1696MHz
  PROCESSOR ID = 06A9
  Unique ID = Disable
  L2 Cache = 256KB * 8
  MSR17 = 0000100000000000
  MSR2A = 0000000000000000
                                     PASS

  Press any key to continue . . .

  Total Fail List
  Error Description

  Fails Found: 0

LOOPBOUND      C.TIME:2012-08-28 14:31:57 COUNT: 01/01 CPU:46C BAT:99%
ORDER:SEQ      custom.log S.TIME:2012-08-28 14:31:53 HALT WAIT PAUSE ; Esc: Break

```

#### 5. CPU Protected Mode Test

This test item is to check whether CPU protected mode instruction works normally.

#### 6. MMX

The test item is to confirm whether the CPU supports MMX instructions.

### Subtest 02 Boards

#### 1. DMA Controller

This test item is to check whether the DMA controller works normally.

#### 2. Interval Timer

This test item is to check whether the Interval Timer (18.2Hz, 55ms) works normally.

#### 3. Clock/Calendar

This test item is to check whether the system clock/calendar works normally.

#### 4. PCI System

This test item is to check whether the bus number, device number and function number in PCI bus are valid.

## 5. Plug and Play

This test item is to check:

1. Whether the current system supports Plug-n-Play;
2. Whether there is an ESCD (Extended System Configuration Data) in the BIOS;
3. Whether there is PCI-to-ISA bridge in the system;
4. Whether there is PCI bus in the system.

**Subtest 03 FAN Speed Test**

## 1. CPU Fan Speed Test

This test item is to check whether the CPU fan currently used works normally in the different speeds of stop, slow, middle and fast.

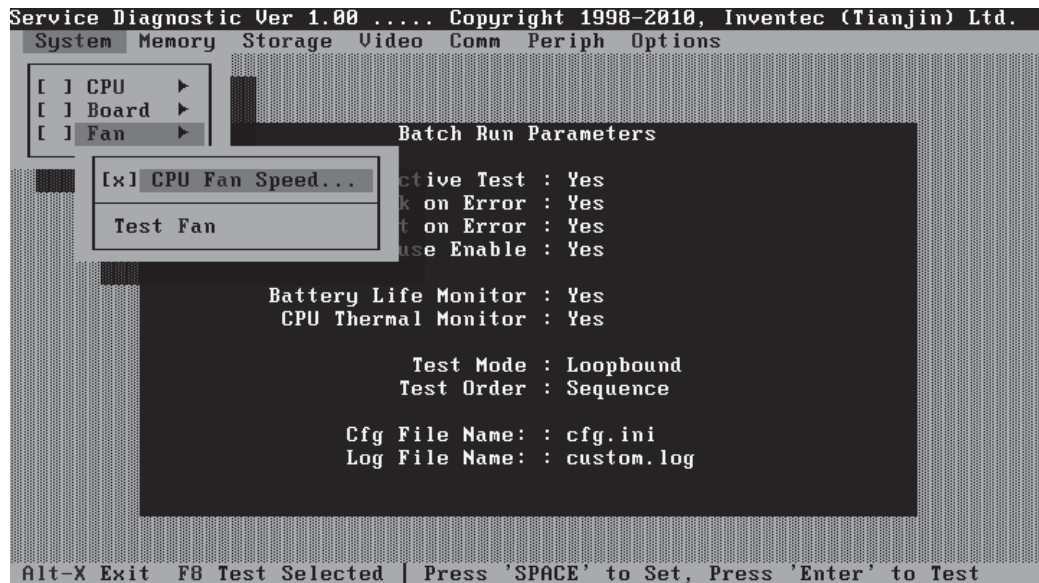

It will be displayed as follows:



## 3.6 Memory Test

This test module is to check whether the memory chip works normally.

### Subtest 01 BIOS ROM

This test item is to check the validity of BIOS ROM that includes two sub-items -- ROM Read and ROM Write Protection. ROM Read is to check whether BIOS ROM could be correctly read out, ROM Write Protect is to check whether BIOS ROM is write-protected.

### Subtest 02 Patterns

This test item is to check whether the system memory includes base memory and extended memory that could be accessed correctly through writing and reading with a series of designed pattern data. Below is the parameter setting dialog window.

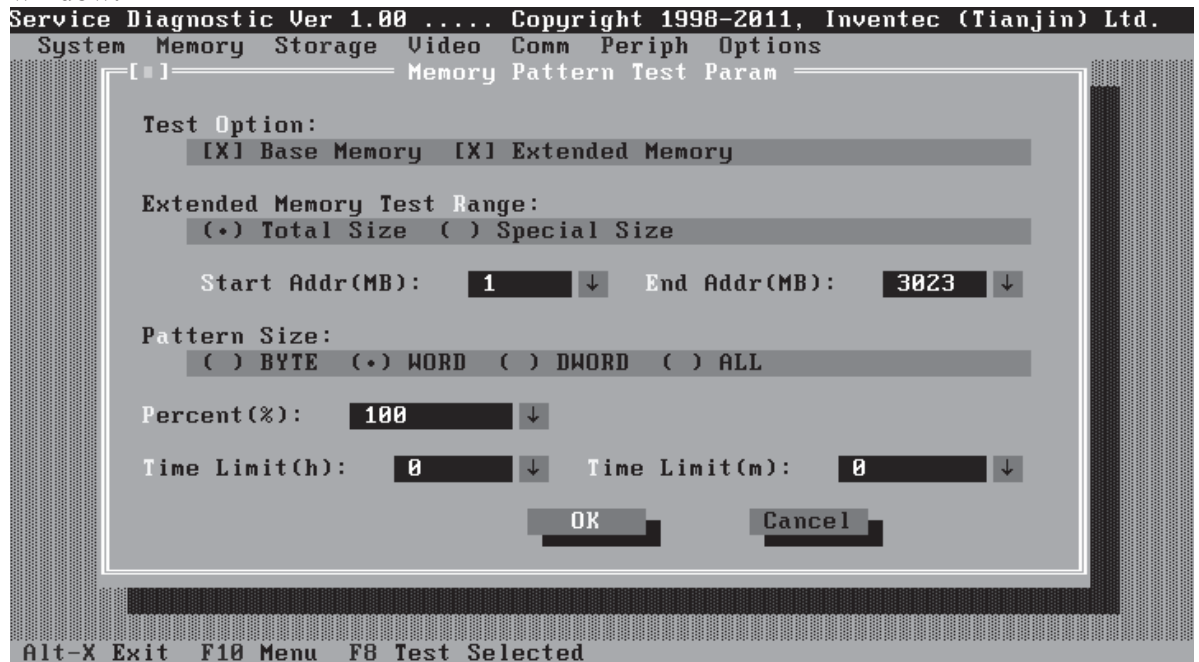

**Test Option:** Choose the Memory part to take the test– Base Memory or Extended Memory.

**Extended Memory Test Range:** Specify the test coverage range of Extended Memory. If user chooses Total Size, it means that the whole Extended Memory will be tested. Although user can input the parameter into other select box, but the selected result is invalid. If user chooses Special Size, the test of Extended Memory will be taken according to the coverage range that user chooses or time.

**Extended Memory Start Address (MB) & Extended Memory End**

**Address (MB):** Set the range of extended memory that is to be tested, the test coverage would be based on the setting and the value in 'Percent (%)' mentioned at below.

**Pattern Size:** Choose the pattern size – BYTE, WORD, DWORD or ALL.

**Percent (%):** Choose the percentage of the defined range of the memory to be tested.

**Time Limit(h):** Choose or Input the time (hour) of the defined range of the memory to be tested.

**Time Limit(m):** Choose or Input the time (minute) of the defined range of the memory to be tested.

## 1. Bit Stuck High Test

Data pattern: Every bit is '1' (Each bit is high)

## 2. Bit Stuck Low Test

Data pattern: Every bit is '0'(Each bit is low);

## 3. Checker Board Test

Data pattern: Lo-byte and hi-byte are composed with 0101(0x5) and 1010 (0xA);

## 4. CAS Line Test

Data pattern: Lo-byte and hi-byte are composed with 0000 (0x0) and 1111(0xF);

## 5. Incremental Test

Data pattern: A series of increasing data from 0 by adding 1 each time;

## 6. Decrement Test

Data Pattern: A series of decreasing data from the maximum (e.g. 0xFFFF) by subtracting 1 each time;

## 7. Incremental / Decrement Test

Data Pattern is a series of data whose low byte is increasing data from 0x00 and high byte is decreasing data from 0xFF.

**Subtest 03      Extended Pattern**

In addition to the above pattern test of the memory, there is Read/Write Cycle test and Read Cycle Test for the extended memory.

Below is the parameter dialog window of the extended pattern test.

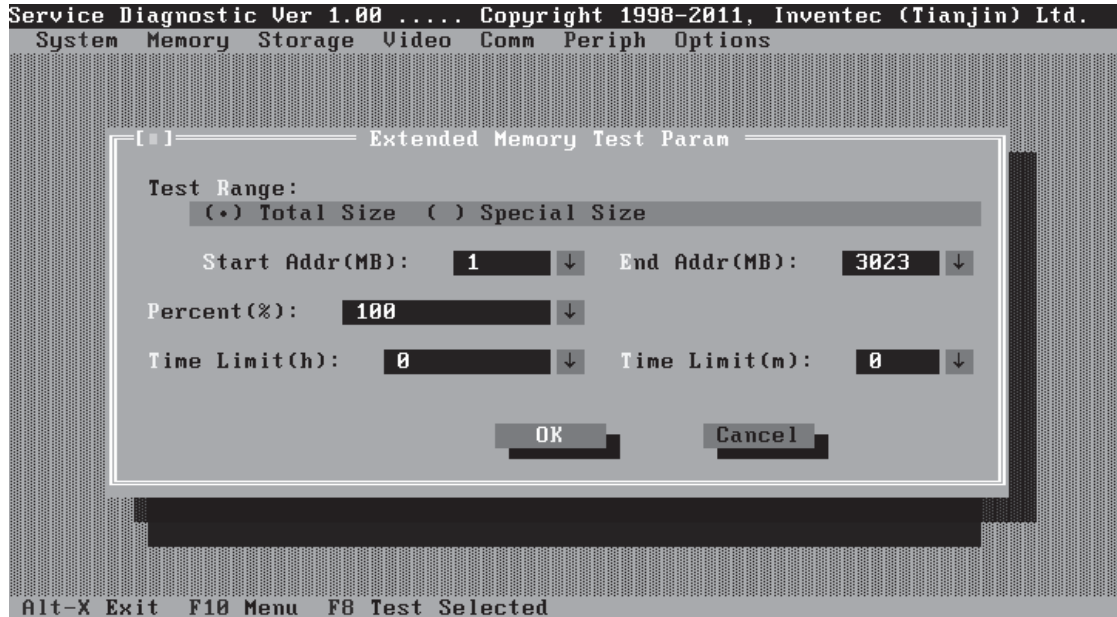

**Test Range:** Specify the test coverage range of Extended Memory. If user chooses Total Size, it means that the whole Extended Memory will be tested. Although user can input the parameter into other select box, but the selected result is invalid. If user chooses Special Size, the test of Extended Memory will be taken according to the coverage range that user chooses or time.

**Extended Memory Start Address and Extended Memory End Address (MB):** Set the range of extended memory that is to be tested. The test coverage will be according to the value setting in 'Percent (%)' mentioned at below.

**Percent (%):** Choose the percentage of the defined range of the memory to be tested.

**Time Limit(h):** Choose or Input the time (hour) of the defined range of the memory to be tested;

**Time Limit(m):** Choose or Input the time (minute) of the defined range of the memory to be tested.

#### 1. Write/Read Cycle Test

Test by using both read and write instructions.

## 2. Read Cycle Test

Test by using read instructions.

### Subtest 04 Walking 1's Test

The test item is to ensure that there is no short circuitry issue in memory chip. The parameter dialog window is the same as that in 'Subtest 02 Pattern'.

### Subtest 05 Walking 0's Test

The test item is to ensure that there is no open circuitry issue in memory chip. The parameter dialog window is the same as that in 'Subtest 02 Pattern'.

### Subtest 06 Memory Address

This test item is to check short and open issue on memory address lines.

### Subtest 07 Refresh Test

This test item is to check whether the memory refresh works normally. The parameter dialog window is as follows:



### Subtest 08 Cache Memory

The test item is to check whether the CPU internal cache memory could be accessed correctly.

### Subtest 09 Random Memory

Random Memory test includes the following two test items: Randomize Test and Random Incremental Read/Write Test. The parameter dialog window is the same as that in 'Subtest 03 Extended Pattern'.

#### 1. Randomize Test

This test item is to check whether the memory could be correctly accessed with randomized data and randomized memory address.

2. Random Increment Read/Write

This test item is to check whether the memory could be correctly accessed with randomized memory address and a series of incremental data.

**Subtest 10 Data Bus Test**

This test item is to check whether the data bus works normally.

**Subtest 11 Bus Noise Test**

This test item is to check whether the bus noise works normally.

**Subtest 12 Memory Speed Test**

This test item is to check the data-transferring rate for the cache memory and the system memory.



## 3.7 Storage

### Subtest 01 HDD

This test item runs on IDE hard disks. It checks the functions and performance of IDE hard disk.

In order to protect user's HDD data, the password must be verified before the HDD test. The screen is as follows:



#### Password: hard disk

##### 1. Sequential/Random R/W

This test item is to check the HDD's Read/Write function through data writing and reading to HDD.

This test item needs user to submit the parameters:

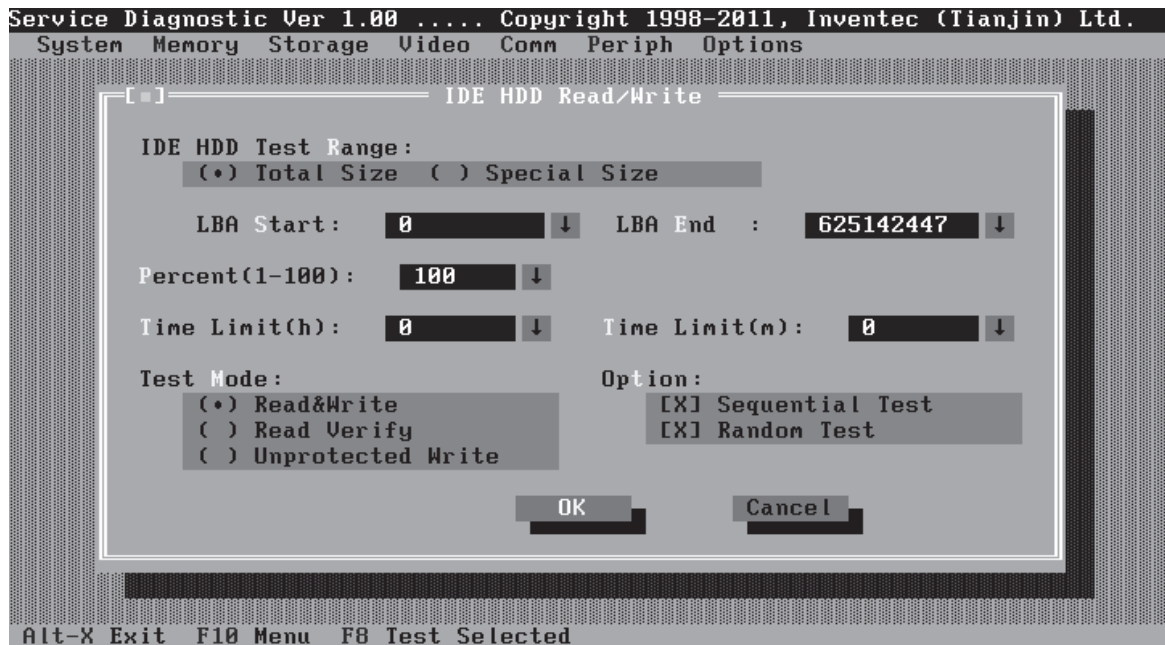

**IDE HDD Test Range--** Specify the test coverage range of IDE HDD. If user chooses Total Size, it means that the whole IDE HDD will be tested. Although user can input the parameter into other select box, but the selected result is

invalid. If user chooses Special Size, the test of IDE HDD will be taken according to the coverage range that user chooses or time.

**LBA Start, LBA End**--Specify the start and end byte in LBA (Large Block Address).

**Percent**—Specify the coverage rate in percentage of the total disk.

**Time Limit(h)**: Choose or Input the time (hour) of the defined range of the total disk to be tested.

**Time Limit(m)**: Choose or Input the time (minute) of the defined range of the total disk to be tested.

**Test Mode**—Choose test mode from the following options:

**(1) Read & Write** –Write data on the disk, then read it out and compare the two value;

**(2) Read Verify** —Read data only;

**(3) Unprotected Write**—Write data on the disk without backup original data.

**Option**—Select sequential test or random test

## 2. Sequential/Random Seek

The test item is to check the correctness of the HDD's sector's seeking function.

This test item involves the following parameters:

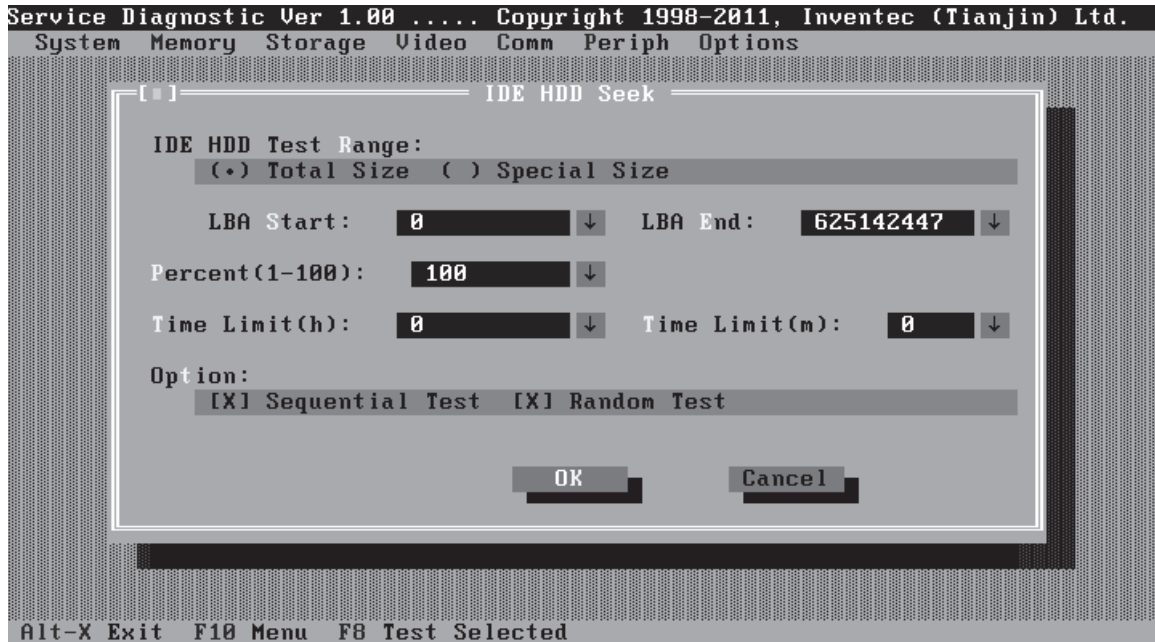

**IDE HDD Test Range**—is same as the description of the upper item.

**LBA Start, LBA End**-- specify start and finish byte in LBA(Large Block Address);

**Option**-- Select sequential test or random test;

**Percent**-- Specify the coverage rate in percentage of the total disk.

**Time Limit(h)**: Choose or Input the time (hour) of the defined range of the total disk to be tested;

**Time Limit(m)**: Choose or Input the time (minute) of the defined range of the total disk to be tested.

### 3. Performance

Check the HDD's seeking speed and transfer the data rate.

### 4. Controller Check

Check the HDD controller's status, including HDD interrupt and unexpected interrupt.

### 5. Diagnostic Read/Write

This test item is a quick test to verify whether the HDD could be correctly accessed and the user could specify the percentage in the below dialog.

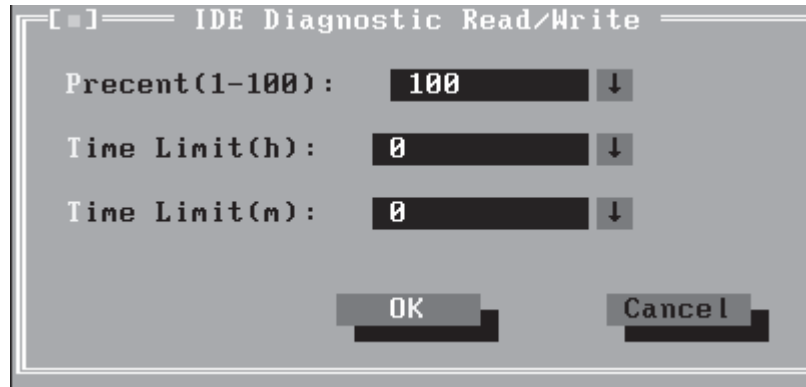

**Percent (1-100)**-- Specify the coverage rate in percentage of the total disk.

**Time Limit(h):** Choose or Input the time (hour) of the defined range of the total disk to be tested;

**Time Limit(m):** Choose or Input the time (minute) of the defined range of the total disk to be tested;

#### 6. SMART Test

SMART stands for Self-Monitoring, Analysis and Reporting Technology. SMART test will compare the attribute values with the threshold value in the HDD's controller to confirm whether there is any failure in the HDD



It would display the below texts of the different attributes in the screen:

1. Text in normal attribute;
2. Text in blinking normal attribute;
3. Text in inverse attribute;
4. Text in blinking inverse attribute;
5. Text in hi-intensity attribute;
6. Text in blinking hi-intensity attribute;

Users need to check whether all texts displayed correctly in the above six attributes and key in the answer 'Y' or 'N' to the prompts 'Is this display OK? [Y/N<Enter=Y>]'.

Below is the test screen of Text Attribute.

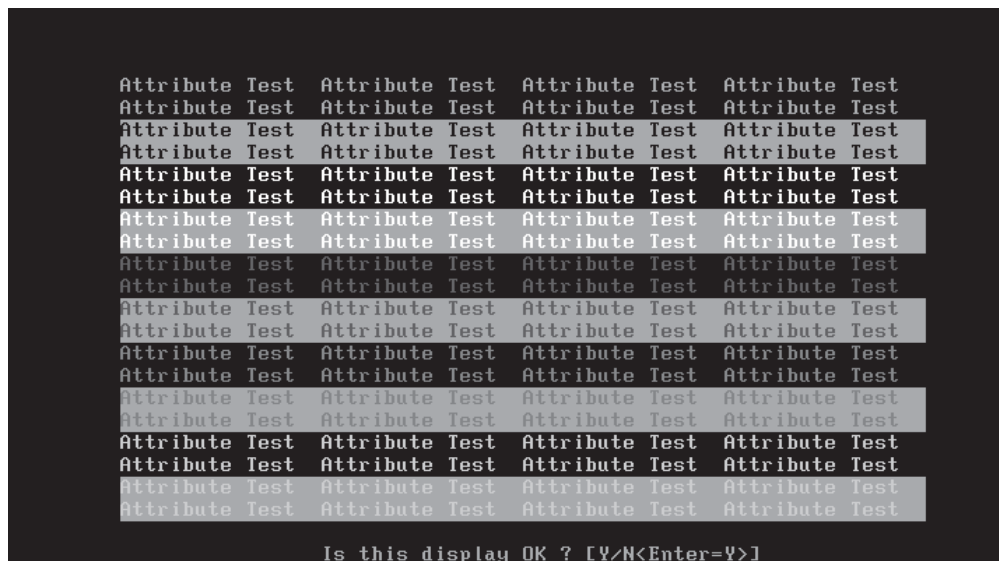

### 3. Text Page Selection

This test item is to check whether the video memory could be correctly written and read in VGA text mode. According to the comparison of written data with read data, the program would report PASS or FAIL.

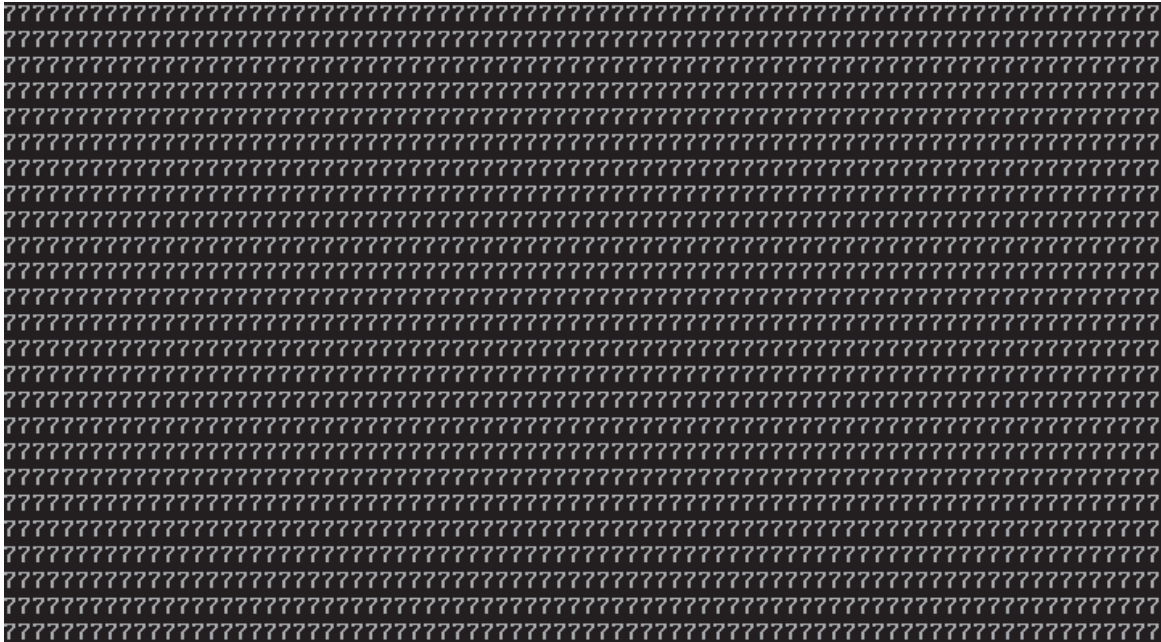

4. Text Color

This test item is to check whether all 16 colors foreground and all 8 colors background works normally in VGA text mode.

The bit4-6 of the attribute byte of a character defines 8 background colors (black, blue, green, cyan, red, brown, magenta, and light gray), and the bit0-3 defines 16 foreground colors (dark gray, light blue, light green, light cyan, light red, light magenta, yellow, and white besides the above 8 colors).

In the test, user is required to respond according to the instruction in the screen.

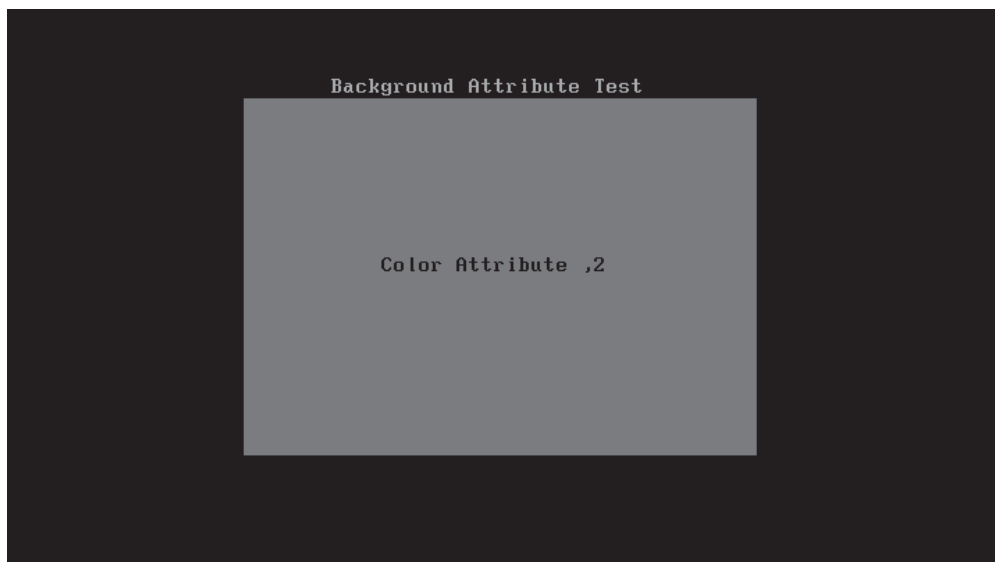

## 5. 80 \* 25 Text Mode

This test item is to check whether 80\*25 Text Mode works normally.

In the test, user is required to respond according to the instruction in the screen.

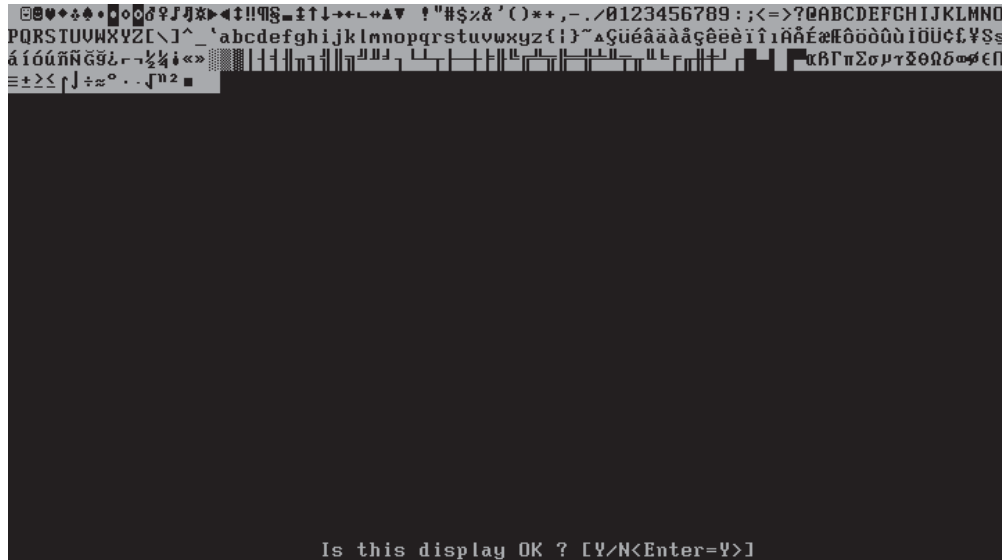
**Subtest 02 640 \* 480 VGA Mode**

This test item is to check whether 680\*480 VGA Text mode works normally.

In the test, user is required to respond according to the instruction in the screen.

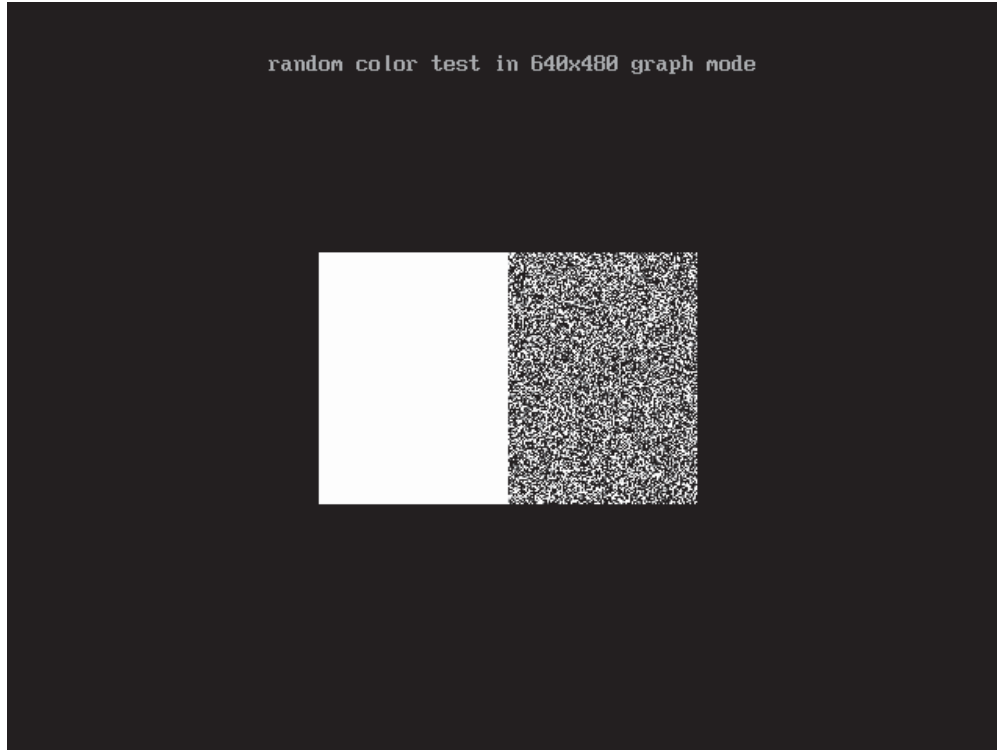

**Subtest 03 VESA Video Modes**

This test item is to check whether all the video modes supported by the video card works normally.

In the test, user is required to respond following the instruction in the screen.

1. 640X480 Video Modes Test

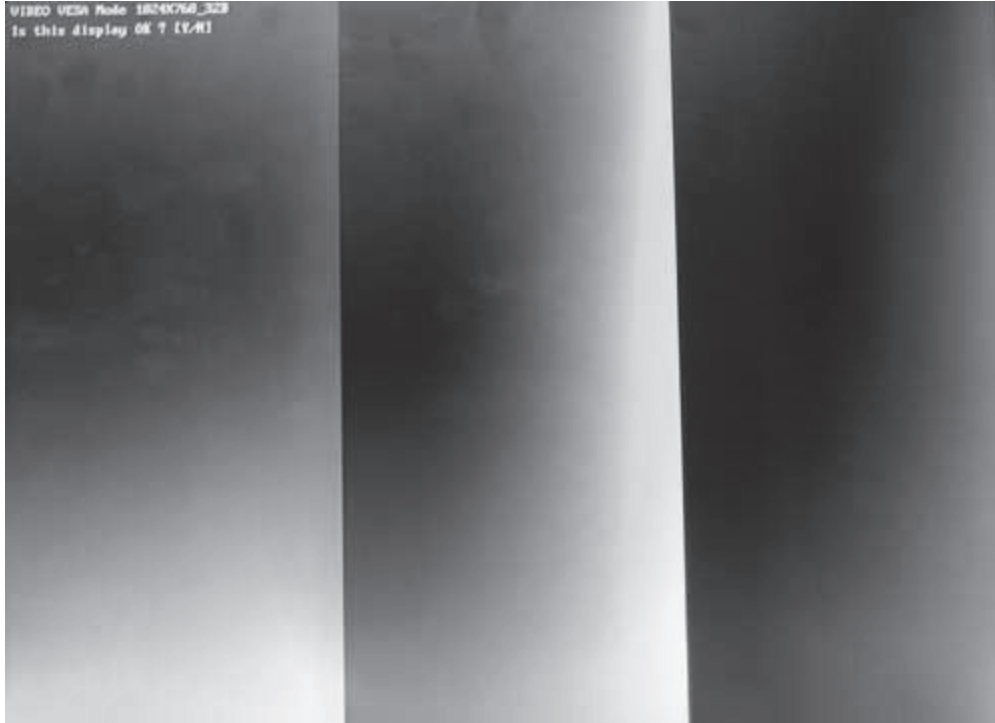

## 2. 800X600 Video Modes Test

### Subtest 04 VESA Video Memory

This test item is to check whether VESA video memory could be correctly accessed (write data & read data). Below is the test item's parameter dialog window:

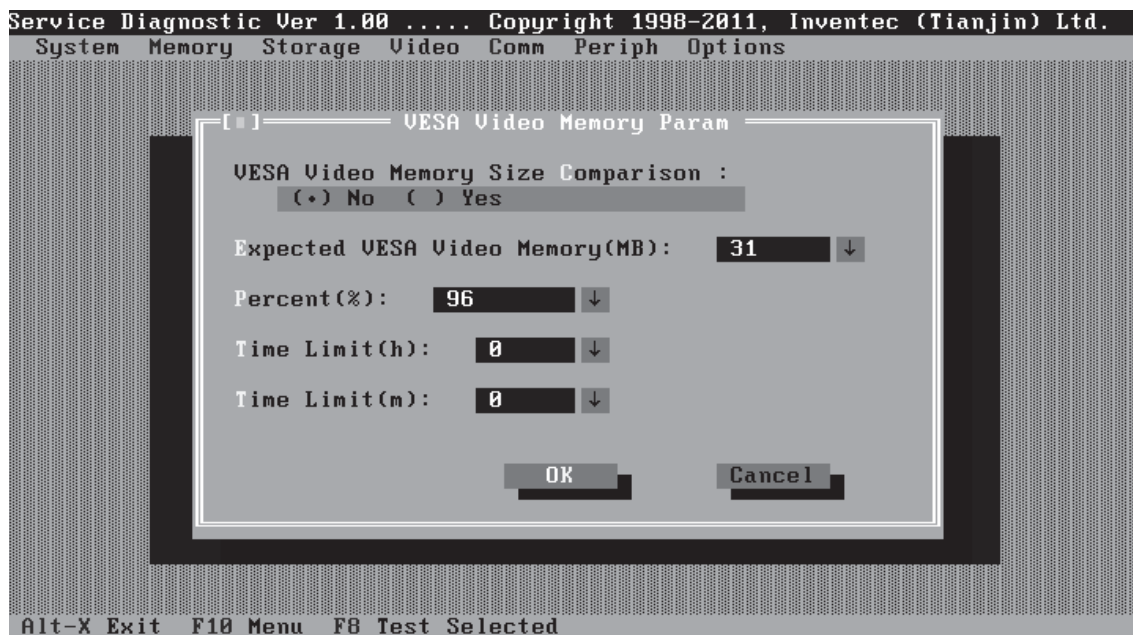

If press Ctrl+Break to force the test to terminate during execution of VESA Video Memory, the test program will not operate and display properly in further tests.

#### **Subtest 05 AGP Test**

This test item is to report the system's Accelerated Graphics Port status and check whether AGP registers works normally.

#### **Subtest 06 LCD Panel Test**

This test item is to check whether there is any fault in its resolution by displaying the RGB gradient color screens.



#### **Subtest 07 Register Test**

This test item is to check whether the registers of the video adapter works normally.

#### **Subtest 08 Color Purity Test**

This test item is to check whether the system (the video adapter and the display) could display the purity color of red, green, blue, black and white.

In the test, user is required to respond according to the instruction in the screen.

#### **Subtest 09 Direct Color Test**

This test item is to check the video adapter's composing ability of direct color in high and true color mode.

In the test, user is required to respond according to the instruction in the screen.

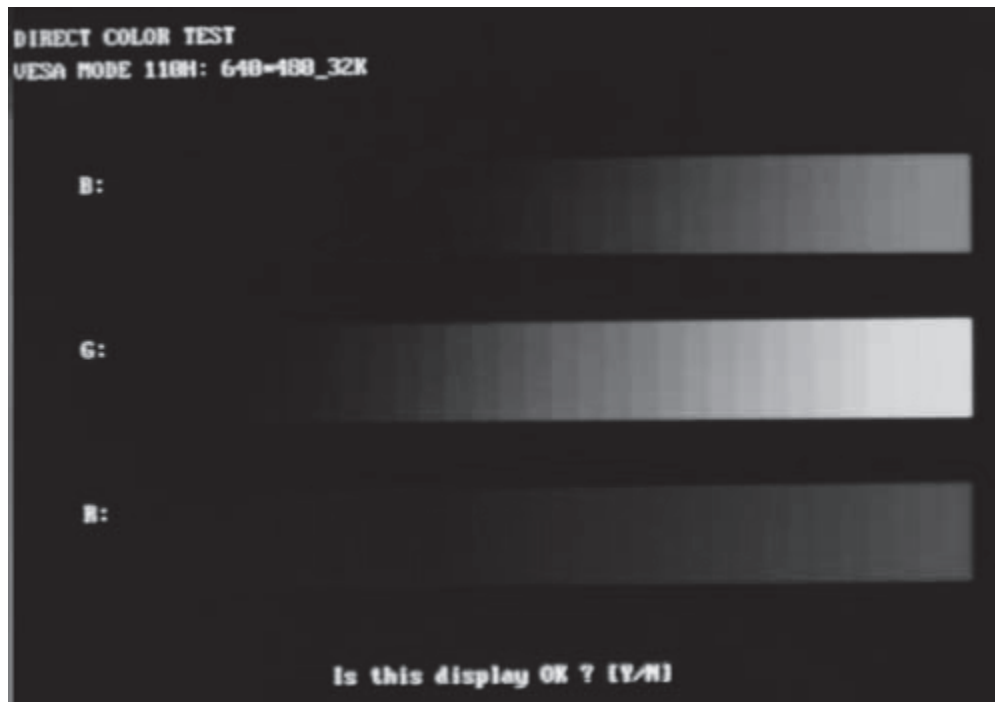

#### **Subtest 10 DAC/Palette Address**

This test item is to check the function of DAC registers and Palette registers.

In the test, user is required to respond according to the instruction in the screen.

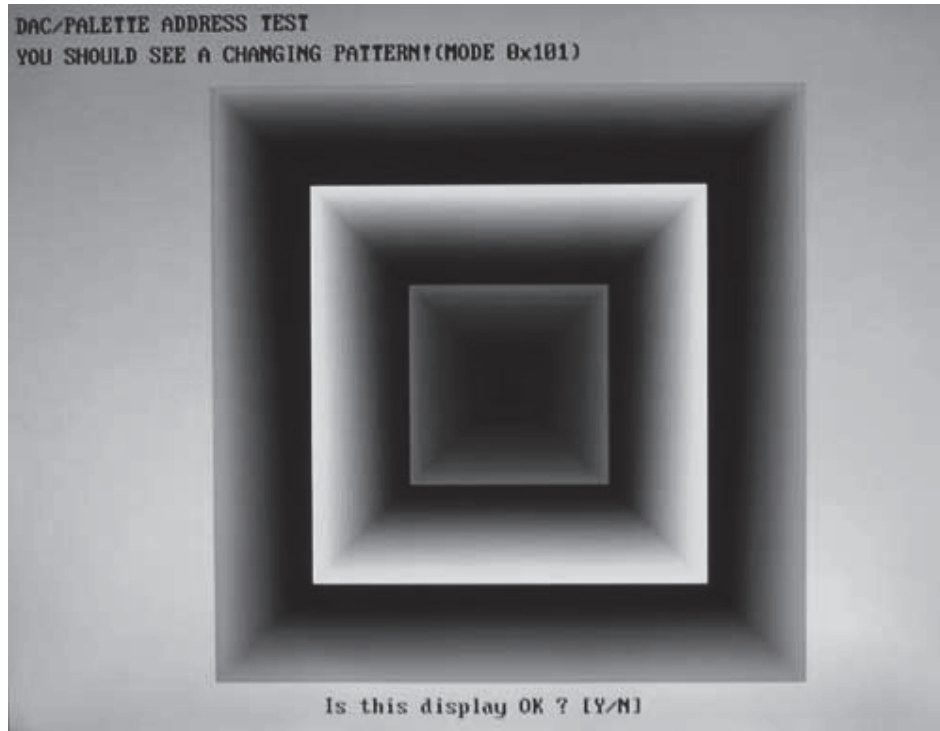

## 3.9 Communication (COMM)

### Subtest 01 LAN Card

This test item is to check whether the module can detect the existence of the network card and display its related information.

1. Device ID Detection

Detect the device ID of the network card.

2. Vendor ID Detection

Detect the vendor ID of the network card.

3. MAC Address Detection

Detect the MAC address of the network card.

## 3.10 Peripheral

### Subtest 01 Keyboard

This test item is to check whether the keyboard works normally.

1. Keyboard Data Line Test

Check whether the keyboard data line works normally.

2. Keyboard Clock Line Test

Check whether the keyboard clock line works normally.

### Subtest 02 Mouse Test

Check whether the point devices work normally.

1. Mouse

Before test Touch Pad's function, user should set a timeout time at below screen:

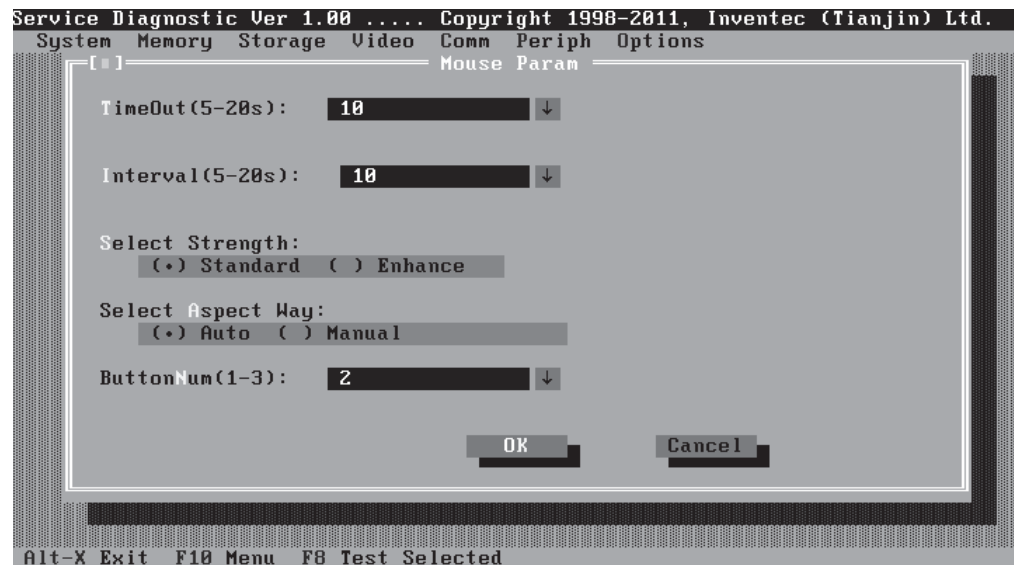

At the below screen of Mouse test, user can press the left button, right button, and move the mouse to verify its functions for times, and the test will end either by user break or test time is out.

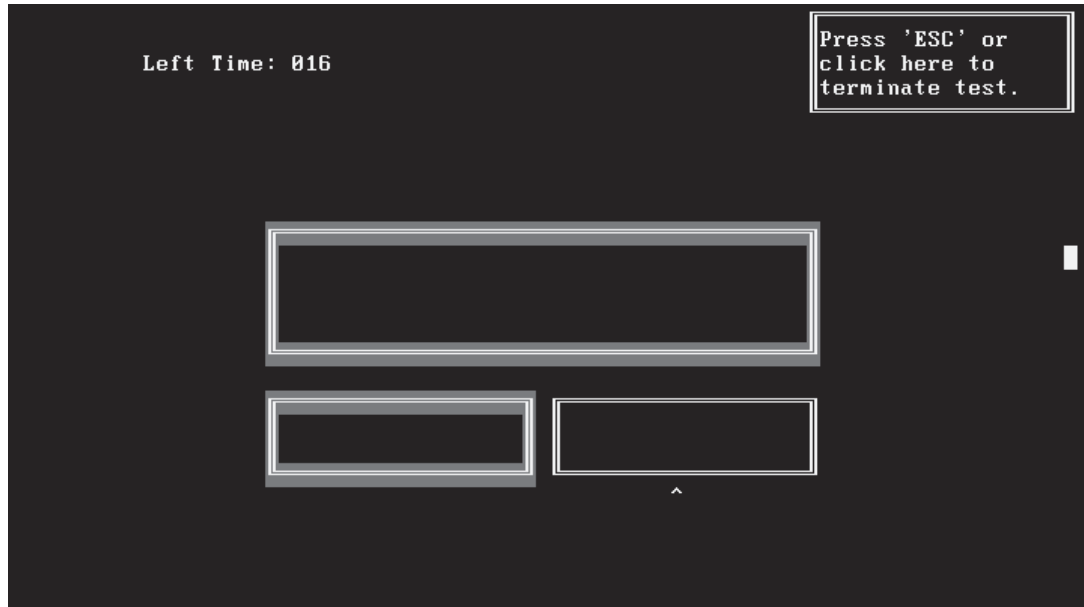

**Subtest 03 Led Test**

1. Led Test

Check whether the white led works normally.

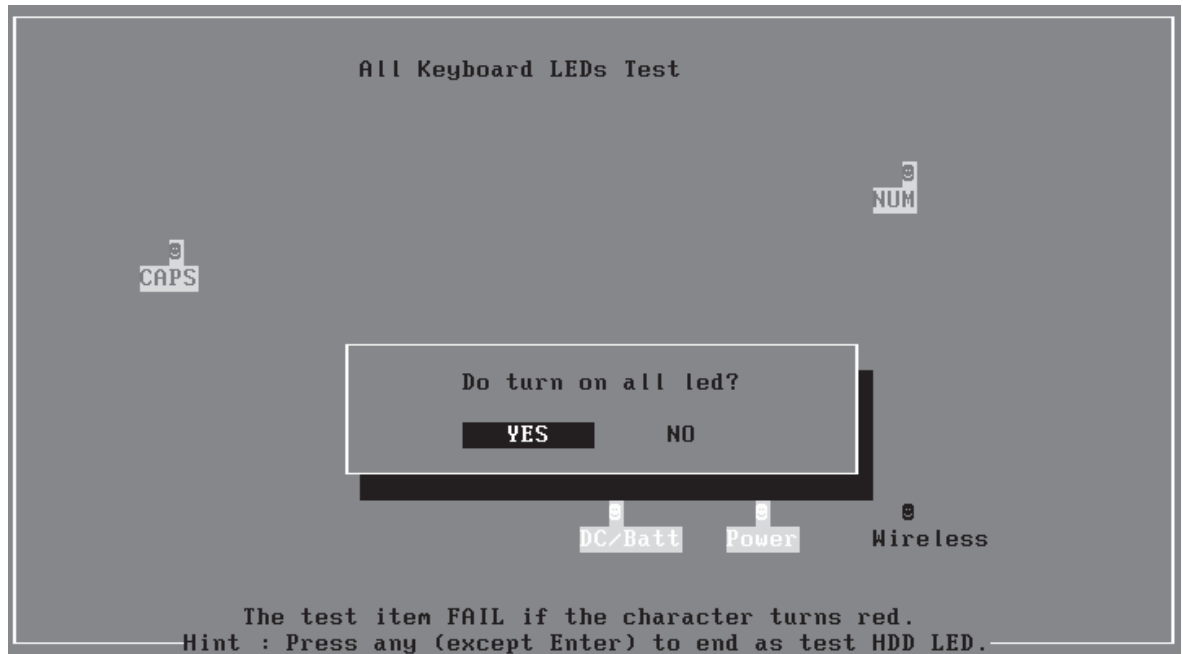



Check whether the orange led works normally.

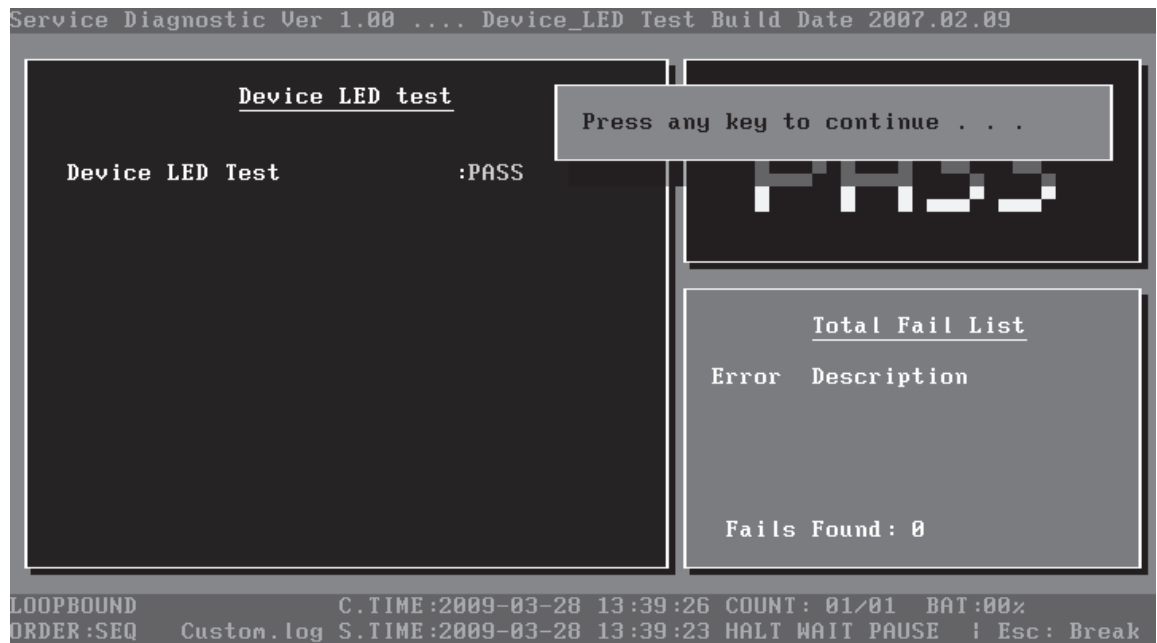
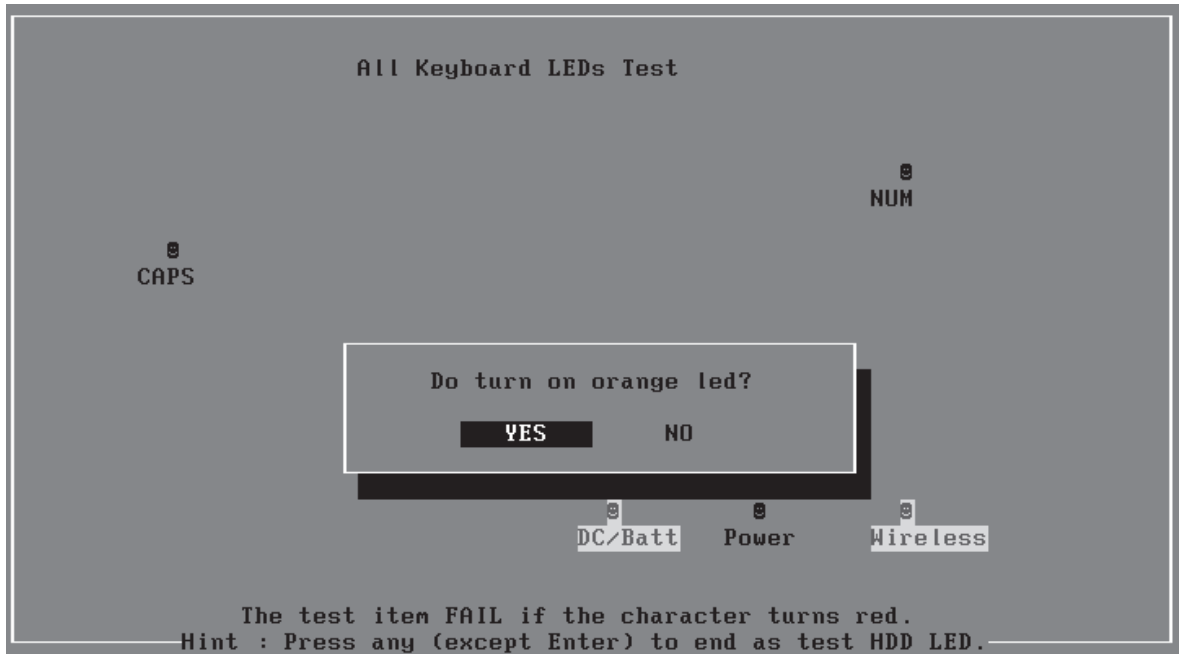

### 3.11 Error Codes and description

The format of 'Error Code' is 'ddxee', and 'dd' is the device ID (1~2 chars), 'xx' is test function ID of device (2 chars), 'ee' is the error code of device (2 chars); the range of error code is from 01 to 99 in each device (the common error codes in all device are set to 99 and spanned).

Device	Error Code	Description	Cause	Action
<b>ddxx</b>	<b>Ee</b>	<b>Common Error</b>		
	94	Interactive Mode Needed	The test is not under interactive mode.	Check whether the interactive test mode is adopted.
<b>01xx</b>		<b>CPU</b>		
	01	CPU General Function Error	The CPU General Function register is damaged.	Replace the CPU.
	02	CPU Arithmetic Error	The CPU Arithmetic Register is damaged.	As above.
	03	CPU Logic Error	The CPU Logic Register is damaged.	As above.
	04	CPU Type Error	The CPU Type is not supportable.	Check whether the CPU is Intel CPU.
	05	CPU Speed Error	The CPU speed differs from the expected value.	Check the CPU speed and the set expected speed.
	06	NPU General Function Error	The NPU arithmetic unit is damaged.	Replace the CPU.
	07	NPU Interrupt Error	The NPU is damaged.	As above.
	08	CPU Information Error	Information of the CPU cannot be acquired.	Check whether the CPU is Intel CPU.
	09	Protected Instruction Error	The CPU is damaged.	Replace the CPU.
	21	MMX Test Error	The CPU MMX register is damaged.	Replace the CPU.
<b>02xx</b>		<b>Memory</b>		
	01	Read Error	The ROM BIOS has Physical problems.	Test this unit on multiple machines.
	02	Write-Protect Error	The ROM BIOS has Physical problems.	As above.
	03	Base Memory Error Address	The test pattern read out from the base memory is different from the one that has been written in this address.	Test this memory chip on multiple machines.

	04	(XMS)Memory Problem	The test pattern read out from the extension memory is different from the one that has been written in this address.	As above.
	05	(XMS) Out Of Range	Wrong parameters setup.	Check and reset the parameters.
	06	Address Test Error	Interference between different address channels.	Test this memory chip on multiple machines.
	07	Toggle Bit Error	Errors with the timer chip.	As above.
	08	Interval Error	The acquired refreshing frequency is out of the estimated range.	Reset the estimated range.
	09	L1 Cache test Error	The pattern read out from the L1 Cache is different from the one that has been written in the same address.	Test this unit on multiple machines.
	12	Data Bus Error	Interference between different data channels.	As above.
	14	Speed Error	Failure during the transfer speed test.	As above.
<b>03xx</b>		<b>Board</b>		
	01	DMA Test Error	DMA channel cannot transfer data normally.	Repeat multiple times. Whether there is always the same error, replace the board.
	04	Interval Timer Error	The difference between the actual precision of the interval timer and its theory value is out of the permitted range. The timer counts imprecisely.	As above.
	05	Periodic Faster Error	The frequency is beyond the standard.	As above.
	06	Periodic Slower Error	The frequency is below the standard.	As above.
	07	Update-ended Interrupt Error	R/W errors with the RTC refreshing interrupt controller.	As above.
	08	RTC Alarm Error	The PC speaker's sound source -- counter/timer 8253 cannot produce corresponding timing signal.	As above.
	13	PCI Bus Error	No PCI.	Check the board.
	14	PCI Bus Scan Error	PCI test fails.	As above.
	15	PCI Device Access Error	PCI access fails.	As above.
	16	PCI Config Verification Error	Wrong PCI configuration.	Check PCI configuration on main board or PCI Device configuration.

	17	PCI to ISA Bridge Error	PCI-ISA bridge errors.	Repeat multiple times. If there is always the same error, replace the board.
	18	ESCD Error	ESCD errors.	As above.
<b>34xx</b>		<b>FAN</b>		
	01	Fan Slow Speed Test Fail	The fan slow speed test fails.	Check the FAN connection.
	02	Fan Stop Test Fail	The fan stop test fails.	As above.
	03	Fan Fast Speed Test Fail	The fan fast speed test fails.	As above.
<b>04xx</b>		<b>Video</b>		
	01	Text Attribute Error	Physical problems with the video card.	Check whether there is any physical problem with the video card.
	02	Text Page Selection Error	As above.	As above.
	03	Text Color Error	As above.	As above.
	04	Text Mode Error	As above.	As above.
	05	VGA Mode Error	1) Physical problems with the video card. 2) Physical problems with the monitor.	1) Check whether there is any physical problem with the video card. 2) Check whether there is any physical problem with the monitor.
	06	Character Test Error	Physical problems with the video card.	Check whether there is any physical problem with the video card.
	07	DAC/Palette Address Test Error	As above.	As above.
	08	Color Purity Test Error	Physical problems with the video card or the monitor.	Check whether there is any physical problem with the video card or the monitor.
	09	VESA Mode 15bits Direct Color Test Error	As above.	As above.
	10	VESA Mode 16bits Direct Color Test Error	As above.	As above.
	11	VESA Mode 24bits Direct Color Test Error	As above.	As above.
	12	Get the PCX graphics map Error	Failure in getting PCX graphics map.	Check for the PCX graphics map.
	13	Bitblt Engine Test Error	Physical problems with the video card.	Check and see whether the video card has any physical problem.
	14	VESA Video Memory Test Error	As above.	As above.
	15	VESA VRAM Test Error	Physical problems with the video card or the monitor.	Check whether there is any physical problem with the video card or the monitor.

	16	AGP Test Error	AGP configuration register errors.	Check and see whether the AGP video card has any physical problem.
	17	LCD Panel Test Error	Lower LCD color resolution.	Replace the LCD.
	19	Register Test Error	Physical problems with the video card.	Check and see whether the video card has any physical problem.
	20	Adapter not support DDC	The video card doesn't support DDC.	
	21	Monitor not support DDC	The monitor doesn't support DDC.	
	21	8bits Text and Attribute Test Error	1) Physical problems with the video card. 2) Physical problems with the monitor.	1) Check and see whether the video card has any physical problem. 2) Check and see whether the monitor has any physical problem.
	26	8bits Video Mode Test Error	As above.	As above.
	27	15bits Video Mode Test Error	As above.	As above.
	28	16bits Video Mode Test Error	As above.	As above.
	29	24bits Video Mode Test Error	As above.	As above.
	30	32bits Video Mode Test Error	As above.	As above.
<b>31xx</b>		<b>Audio</b>		
	01	Audio Play Fail	Cannot play music.	Check the Audio connection, replace the external fixture, and repeat the test.
	02	Record Fail	Cannot record.	As above.
<b>08xx</b>		<b>LAN Card</b>		
	01	PCI bus Error during device ID test	Don't Scan PCI device	Don't support PCI BIOS
	02	PCI Ethernet card not present during device ID test	Don't find Net card	Please insert Net cad
	03	Intel PCI Ethernet card not present during MAC test	Don't found Net Card, This Card can't be Read MAC by this method	Please update net card or use other method
<b>09xx</b>		<b>Keyboard</b>		
	01	Keyboard Map & Stroke Test Fail	Keyboard Map & Stroke Test fails.	Check the KBD connection and repeat the test.
	03	Clock Line Test Fail	Clock Line Test fails.	As above.
	04	Data Line Test Fail	Data Line Test fails.	As above.

<b>05xx</b>		<b>Mouse</b>		
	01	Touch Pad Test Fail	Touch Pad Test Fail	Check the mouse connection and repeat the test.
<b>20xx</b>		<b>IDE-HDD</b>		
	01	Get Parameter Fail !	Wrong test parameters are input by user.	Reinput the correct parameters.
	02	Write Pattern Error	HD is damaged.	Send the HD for repair.
	03	Data Compare Error	HD is damaged.	As above.
	04	Read Verify Error	HD is damaged.	As above.
	05	Seek Error	HD is damaged.	As above.
	06	Disk Controller Self Test Failed	The HD controller is damaged.	As above.
	07	Disk Controller Test unexpected interrupt Failed	The HD controller is damaged.	As above.
	09	Disk Controller action Test Failed	The HD controller is damaged.	As above.
	10	Disk dos not support SMART	Disk dos not support SMART	Change HD which supported SMART and test again
	11	Disk read attribute threshold error	Disk read attribute threshold error	Send the HD for repair.
	12	Disk read attribute value error	Disk read attribute value error	As above.
	13	Disk SMART attribute value error	Disk SMART attribute value error	As above.

### 3.12 Quick Test Item List

Device	Test Items	Comment
CPU	Basic Functionality	
	NPU Basic Functions	
	CPU Information	
Memory	Cache Memory	
	Bit Stuck High Test	10% or 3 minutes
	Bit Stuck Low Test	10% or 3 minutes
	Address Test	
Board	Interval Timer	
	Clock / Calendar	
FAN	FAN Speed	
Video	1024 x 768 Video Modes Test: VESA1024 x 768 x64K Mode VESA1024 x 768 x32bit Mode	
	VESA Video Memory	10% or 3 minutes
	Color Purity Test	
	Direct Color Test	
	LCD Panel	
HDD	Sequential/Random Read	25% or 3 minutes
	SMART Check	
LAN Card	Device ID Detection	
	Vendor ID Detection	
	Mac Address Detection	

---

## **Chapter 4**

# **Replacement Procedures**

---





---

## Chapter 4 Contents

---

4.1	General .....	4-1
	Safety Precautions .....	4-2
	Before You Begin.....	4-4
	Disassembly Procedures .....	4-5
	Assembly Procedures .....	4-5
	Tools and Equipment.....	4-6
	Screw Tightening Torque .....	4-6
	Colors of Screw Shanks .....	4-7
	Symbols of Screws on the Computer Body.....	4-7
	Symbol examples .....	4-7
4.2	Battery Pack/Bridge Media .....	4-8
	4.2.1 Battery Pack.....	4-8
	Removing the Battery Pack .....	4-8
	Installing the Battery Pack.....	4-9
	4.2.2 Bridge Media.....	4-10
	Removing the Bridge Media .....	4-10
	Installing the Bridge Media .....	4-10
4.3	Memory Module and RTC Battery .....	4-11
	Remove the Memory Module and RTC Battery.....	4-11
	Installing the Memory Module and RTC Battery.....	4-12
4.4	HDD .....	4-13
	Removing the HDD.....	4-13
	Installing the HDD .....	4-14
4.5	ODD Bay Module .....	4-15
	Removing the ODD Bay Module.....	4-15
	Installing the ODD Bay Module .....	4-16
	Disassembling the ODD Drive .....	4-17
	Assembling the ODD Drive.....	4-17
4.6	Keyboard.....	4-18

## 4 Replacement Procedures

---

	Removing Keyboard.....	4-18
	Installing the Keyboard .....	4-20
4.7	Wireless LAN Card.....	4-21
	Removing the Wireless LAN Card.....	4-21
	Installing the Wireless LAN Card.....	4-24
4.8	CPU Cooling Module and Fan.....	4-25
	Removing the CPU Cooling module and Fan .....	4-25
	Installing the CPU Cooling Module and Fan .....	4-27
4.9	System Board .....	4-28
	Removing the System Board.....	4-28
	Installing the System Board.....	4-30
4.10	LCD Module Assembly .....	4-31
	Removing the LCD Module Assembly .....	4-31
	Installing the LCD Module Assembly.....	4-32
4.11	LCD Module Mask .....	4-33
	Remove the Display Mask.....	4-33
	Installing the Display Mask.....	4-34
4.12	LED Panel .....	4-35
	Removing the LED Panel.....	4-35
	Installing the LED Panel .....	4-37
4.13	CCD Module.....	4-38
	Removing the CCD Module.....	4-38
	Installing the CCD Module .....	4-39
4.14	Speakers .....	4-40
	Removing the Speaker.....	4-40
	Installing the Speaker .....	4-40
4.15	Power Board, USB Board and DC-IN harness .....	4-41
	Removing the Power Board, , USB Board and DC-IN Harness .....	4-41
	Installing the Power Board, USB Board and DC-IN Harness .....	4-41
4.16	Touchpad Board.....	4-42
	Removing the Touchpad Board.....	4-42
	Installing the Touchpad board.....	4-42

## Figures

Figure 4-1 Removing the battery pack .....	4-8
Figure 4-2 Removing the Bridge Media .....	4-10
Figure 4-3 Removing the Memory Module and RTC Battery .....	4-11
Figure 4-4 Removing the HDD pack .....	4-13
Figure 4-5 Removing the HDD chassis .....	4-14
Figure 4-6 Removing the ODD Bay Module.....	4-15
Figure 4-7 Removing the bracket from the ODD drive.....	4-17
Figure 4-8 Removing the keyboard .....	4-18
Figure 4-9 Removing the screws on the top cover.....	4-21
Figure 4-10 Removing the bottom cover.....	4-22
Figure 4-11 Removing the wireless LAN card .....	4-23
Figure 4-12 Removing the CPU cooling module and Fan .....	4-25
Figure 4-13 Applying silicon grease .....	4-26
Figure 4-14 Removing the cables on the System Board .....	4-28
Figure 4-15 Removing the System Board .....	4-29
Figure 4-16 Removing the display assembly .....	4-31
Figure 4-17 Removing the LCD Module Mask .....	4-33
Figure 4-18 Removing the LCD module hinges, LED Panel and LED panel brackets....	4-35
Figure 4-19 Removing the LCD cable .....	4-36
Figure 4-20 Removing the CCD Module .....	4-38
Figure 4-21 Removing the speakers .....	4-40
Figure 4-22 Removing the Power board, USB board and DC-IN Harness .....	4-41
Figure 4-23 Removing the Touchpad board .....	4-42



---

---

## 4.1 General

This chapter explains how to disassemble the computer and replace Field Replaceable Units (FRUs). Some replacement procedures may not require you to remove all the surrounding FRUs to replace only one FRU. The chart below shows the FRUs in the order in which they should be removed in a top-down manner, irrespective of their physical locations. The FRUs shown in the top area of the chart should normally be removed before removing the FRUs shown in the bottom area. To replace the FRUs, first identify the suspect FRU for the system failure. Next, according to this chart, determine the FRUs that need to be removed before removing the suspect FRU. After you determine those FRUs, go to the appropriate sections according to the section numbers shown in the boxes. Then start removal and replacement.

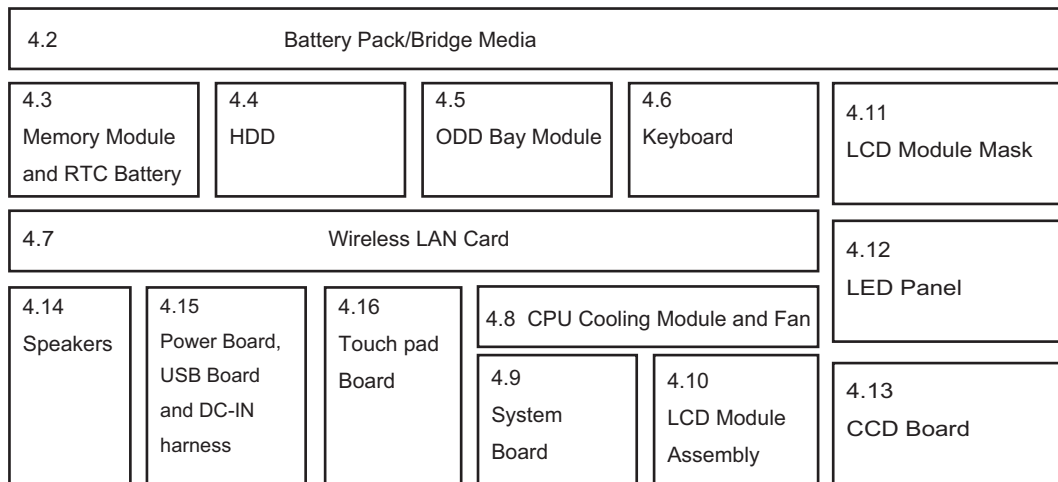

How to use the chart (two examples):

- For removing the System Board:

First, remove the top cover with the display assembly. Then, remove the HDD, selectable bay module, Bluetooth card, keyboard, and wireless LAN card, all of which are shown above the top cover with the display assembly.

- For removing the LCD Module:  
First, remove the display mask, both of which are shown above the LCD module.

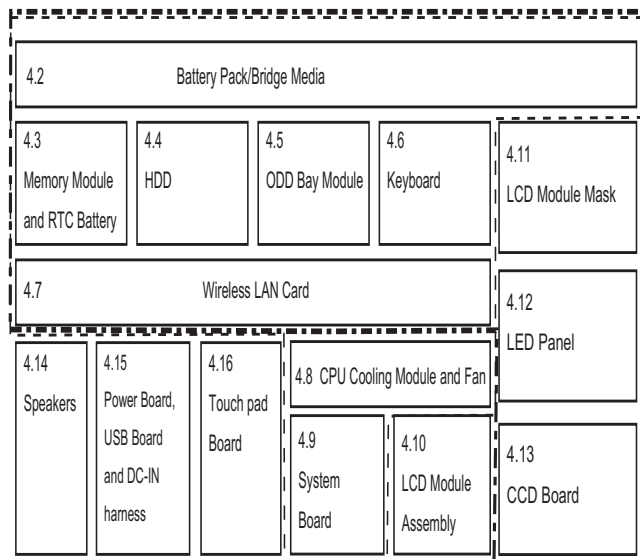

- - - System Board  
- - - LCD module

## Safety Precautions

Before you begin to disassembly read the following safety precautions carefully. Be sure to follow them while you are working.

**DANGER:**

1. *Always use the genuine batteries or replacement batteries authorized by Toshiba. Batteries other than those differ in specifications and are incompatible with the computer. They may burst or explode. To avoid leakage of alkaline solutions, never heat or disassemble the battery packs. Never throw the battery packs into a fire. If this is violated, they will explode.*
2. *The components such as the power supply and FL inverter carry high voltages. When you partially disassemble the computer and turn on the components, use extreme care not to touch the connectors and components to avoid the risk of electrical shock. Do not disassemble individual components during first-level maintenance.*

**WARNING:**

1. *To avoid the risk of electrical shock, turn the computer off and remove the AC adapter from the electrical outlet.*
2. *Because the battery in the computer is left charged, the risk of electrical shock remains even after the AC adapter is removed from the electrical outlet. To avoid the risk of electrical shock, be sure to remove any metal jewelry or accessories such as necklaces, bracelets, and rings before starting work. Never work with damp or wet hands.*
3. *To avoid personal injury, use care to avoid the sharp edges or corners of the components.*



**CAUTION:**

1. *Before replacing a component, make sure that the replacement component meets the required specifications. To avoid computer failures, never use components that do not meet the specifications.*
2. *To avoid internal damage such as short circuits and fire, never drop metal objects such as screws, pins, paper clips, etc. into the components. When a screw is removed, be sure to replace a screw that is the same size as the original screw. Make sure that all the screws are fastened securely. Loose screws can cause short circuits, overheating, smoke, or fire.*
3. *Before raising a FRU or other component, make sure that all the component cables have been disconnected to avoid the risk of electrical shock caused by accidental contact with the energized components.*
4. *For AC input, be sure to use the AC adapter and AC power cable that come with your computer or Toshiba-recommended equivalents.*
5. *To avoid the risk of electrical shock, make sure that all the replacement components meet the specifications of the computer and that all the cables and connectors are fastened securely.*
6. *Inside the PC are components that become hot during operation (such as the CPU and cooling module). To avoid burns, let the hot components cool down before starting inspection or repair task.*

### **Before You Begin**

Before you begin to disassembly the computer, keep in mind the precautions and advice in this section. Always begin disassembly by removing the AC adapter and battery pack. Remove the optional parts and accessories as well. The procedures for removing the batteries will be explained later.

Disassemble the computer only when an abnormality has occurred.

Use only the recommended tools.

To run and store the computer, be sure to prepare a working environment that is free from:

- Dust and contaminants
- Static electricity
- Extremely high or low temperatures and extremely high humidity

Run the diagnostic tests explained in Chapter 2 of this manual to identify the FRU that has probably caused the system failure.

Perform only the required machine operations. Use only the disassembly and reinstallation procedures described in this manual.

Place the removed components in a safe place away from the computer so that they are not damaged or get in the way of you doing your work.

Normally, a number of screws need to be removed or replaced during disassembling. Place the removed screws in a safe place so that you can easily find the right screws for the right components.

When assembling the computer, use the specified screws to fasten the parts to the specified locations. See the appropriate explanations and figures for screw sizes.

To avoid personal injury, use care to handle components that have sharp edges or corners.

After you have replaced a FRU, check that the FRU works correctly to ensure normal computer operation.

### Disassembly Procedures

The cable connectors come in these two basic types:

- Pressure plate connectors
- Normal pin connectors

To remove a pressure plate connector, pull up the tabs on either side of the connector's plastic pressure plate and gently pull the cable out of the connector. To reconnect the cable to the pressure plate's connector, raise the pressure plate up to a satisfactory height and slide the cable into the connector. Secure the cable in the correct position by pressing down the sides of the pressure plate so that the plate is flush with the sides of the connector. Grasp and pull the cable gently to check that the cable is connected firmly. If the cable comes off the connector, reinsert the cable by raising the pressure plate up to a satisfactory height.

Normal pin connectors are used for all the other types of cables. These connectors can be installed or removed by simply inserting them or pulling them out.

### Assembly Procedures

You have to reassemble the computer after you have disassembled the computer and fixed the component that caused the problem.

When reassembling the computer, keep the following general guidelines in mind:

- Take your time to carry out the suggested instructions completely. Hurried reassembly can often cause problems.
- Check that all the cable and connectors are fastened securely.
- Before securing the FRUs or other parts, check that the cables are not caught by the screws or FRUs.
- Check that all the latches are closed securely.
- Check that all the required screws are used to secure the FRUs. Using wrong screws can damage the threads or heads of the screws or does not ensure that the FRUs are secure.

After installing a FRU, make sure that the FRU and computer work normally.

## Tools and Equipment

For your safety and that of other people in the working environment, it is strongly recommended that you use electrostatic discharge (ESD) equipment. The proper use of this equipment will ensure successful repair work and reduce the costs for repairing damaged components. The equipment and tools required for disassembly and reassembly are:

- One 2 mm Phillips screwdriver
- One 4 mm flat-blade screwdriver
- Torx screwdriver
- Tweezers (for pulling out screws)
- ESD mats (for the floor and work desks)
- An ESD wrist strap or heel grounder
- Anti-static carpets or flooring
- Air ionizers (for highly electrostatic sensitive areas)
- A plastic card (in credit card size)

## Screw Tightening Torque

To secure screws, follow the torque values listed below. Over tightening can damage components and screws. Under tightening can loosen the screw or cause screws to come off, which may result in short circuits or other damage.

- |  |                        |
|--|------------------------|
| <input type="checkbox"/> M2 (2 mm)               | 0.22 N·m (2.2 kgf·cm)  |
| <input type="checkbox"/> M2.5 (2.5 mm)           | 0.36 N·m (3.5 kgf·cm)  |
| <input type="checkbox"/> M3 (3 mm)               | 0.51 N·m (5.0 kgf·cm)  |
| <input type="checkbox"/> M2.5x4 PSP TITE screws  | 0.204 N·m (2.0 kgf·cm) |
| <input type="checkbox"/> M2.5x6 GIZA TITE screws | 0.36 N·m (3.5 kgf·cm)  |

### Colors of Screw Shanks

For easy identification of the correct screws, the screw shanks are colored according to their lengths, as follows:

- Screws of an even-numbered length      Brown
  - Screws of an odd-numbered length      White
  - Screws of a special length      Black
- Screws of a special length are those of a length having decimal places, such as 2.5 mm and 2.6 mm.

### Symbols of Screws on the Computer Body

For easy maintenance, the screw types are shown on the computer body as symbols. A symbol consists of a letter representing the screw type and a numeral representing the screw length.

- Screw type      Letter
- Bind screw      B (stands for bind)
- Flat-head screw      F (stands for flat-head)
- Super flat-head screw      S (stands for super flat-head)
- Tapping screw      T (stands for tapping)
- Other screws      U (stands for unique-pan head screws, studs, etc.)

### Symbol examples

- 6 mm bind screw      B6
- 12 mm bind screw      B12
- 5 mm stud      U5

(The numeral represents the rounded length of the threaded portion regardless of the entire stud length.)

## 4.2 Battery Pack/Bridge Media

### 4.2.1 Battery Pack

#### Removing the Battery Pack

Remove the Battery Pack according to the following procedures and Figure 4-1.

**CAUTION:** When handling the Battery Pack, use care not to short circuit the terminals. Do not drop, hit, twist, or bend the Battery Pack. Do not scratch or break up their casing.

1. Turn the computer upside down so that the back is facing you.
2. Slide out the battery lock.
3. Slide the battery release latch and remove the Battery Pack from the computer.

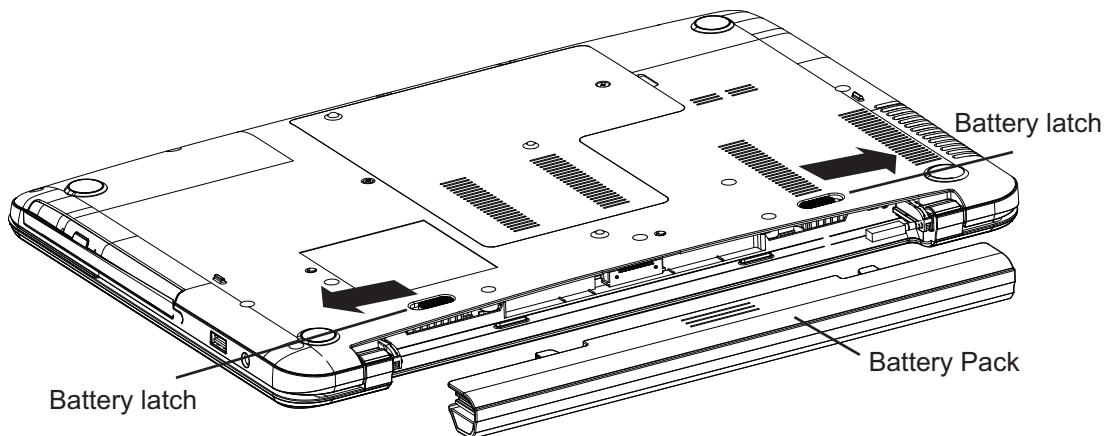

Figure 4-1 Removing the Battery Pack

**NOTE:** Dispose of the used Battery Pack as required by local ordinances or regulations.

### Installing the Battery Pack

Install the Battery Pack according to the following procedures and Figure 4-1.

***CAUTION: The Battery Pack contain a lithium ion battery, which can explode due to improper replacement, use, handling, or disposal. Always dispose of the Battery Pack as required by local ordinances or regulations. Use only replacement batteries recommended by Toshiba.***

***NOTE: Visually check the battery's terminals. If they are dirty, clean them with a dry cloth.***

1. Gently insert a new or recharged Battery Pack into place. Check that the battery release latch slides in and stops with a click.
2. Slide in the battery lock.

### 4.2.2 Bridge Media

#### Removing the Bridge Media

Remove the Bridge Media according to the following procedures and Figure 4-2, after checking that the computer is turned off in boot mode.

1. Pull out the part of Bridge Media when you release.

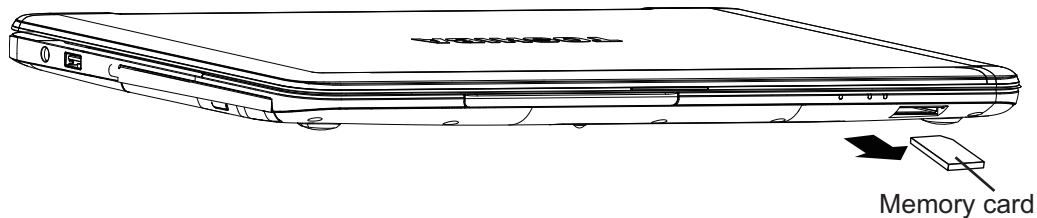

*Figure 4-2 Removing the Bridge Media*

#### Installing the Bridge Media

Install the Bridge Media according to the following procedures and Figure 4-2, after checking that the computer is turned off in boot mode.

1. Insert a Bridge Media and press it until it is securely connected.

After the Bridge Media is installed, check the hardware configuration in the Hardware Setup or TSETUP program to make sure that the Bridge Media is compatible with the current hardware configuration.



### 4.3 Memory Module and RTC Battery

#### Remove the Memory Module and RTC Battery

Remove the Memory Module and RTC Battery according to the following procedures and Figure 4-3, after checking that the computer is turned off in boot mode.

**CAUTION:** Remove the optional memory after turning off the computer. If this is violated, the computer or memory can be damaged.

1. Turn the computer upside down.
2. Release one memory HDD cover securing the screw.
3. Release 8 latches on the memory HDD cover by twist in clockwise direction.
4. Remove the memory HDD cover.

**CAUTION:** Do not touch the connectors on the Memory Modules or in the computer. Contaminated connectors can cause memory access problems.

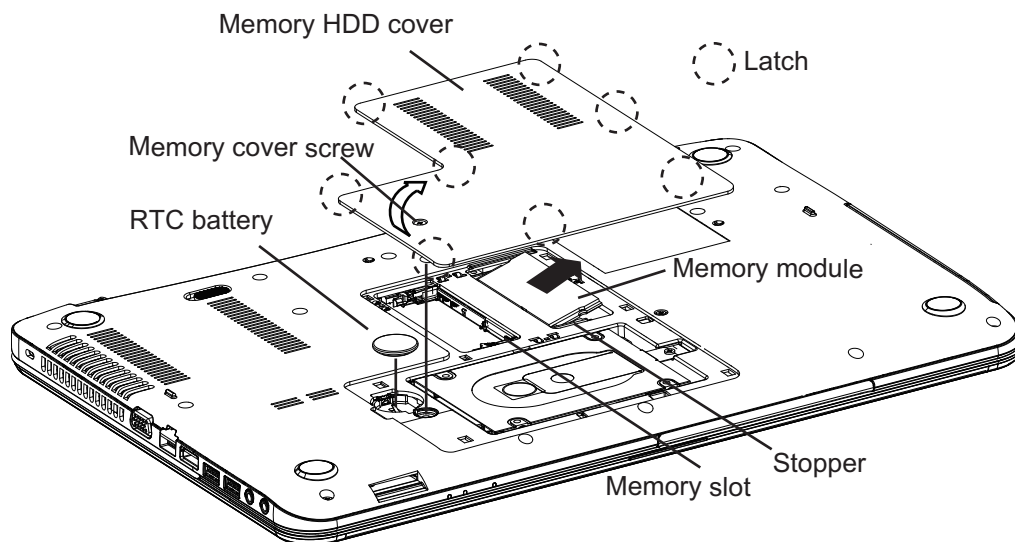

Figure 4-3 Removing the Memory Module and RTC Battery

5. Spread out the two memory lock latches so that the Memory Module pops up.
6. Pull the Memory Module up and out at an angle, using care to avoid touching the connectors.
7. Release RTC Battery with spread out the RTC Battery latch.
8. Remove RTC Battery.

### Installing the Memory Module and RTC Battery

Install the Memory Module and RTC Battery according to the following procedures and Figure 4-3, after checking that the computer is turned off in boot mode.

***CAUTION: Install the optional memory after turning off the computer. If this is violated, the computer or memory can be damaged.***

1. Place RTC Battery in battery locker in the correct position.
2. Insert the Memory Module into the connector at an angle of 45 degrees.
3. Press down the Memory Module so that it is secured with both memory lock latches.
4. Reinstall the optional memory HDD cover.
5. Secure the optional memory cover with the optional memory cover securing screw.

After the computer is turned on, check the hardware configuration in the Hardware Setup or TSETUP program to make sure that the installed Memory Module has been recognized by the system. If it has not been recognized yet, check the connections.

## 4.4 HDD

### Removing the HDD

**CAUTION:** Do not press on the top or bottom of the drive. Applying such pressure can either corrupt the data in the drive or damage the drive.

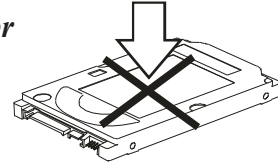

Remove the HDD (hard disk drive) according to the following procedures and Figures 4-4 and 4-5.

1. Release the M2.5x6 black flat head screw securing the HDD pack.
2. Pull the HDD pack for disconnect the computer, using care to avoid touching the connectors.
3. Remove the HDD pack by pulling the pack, following the direction of the arrows.

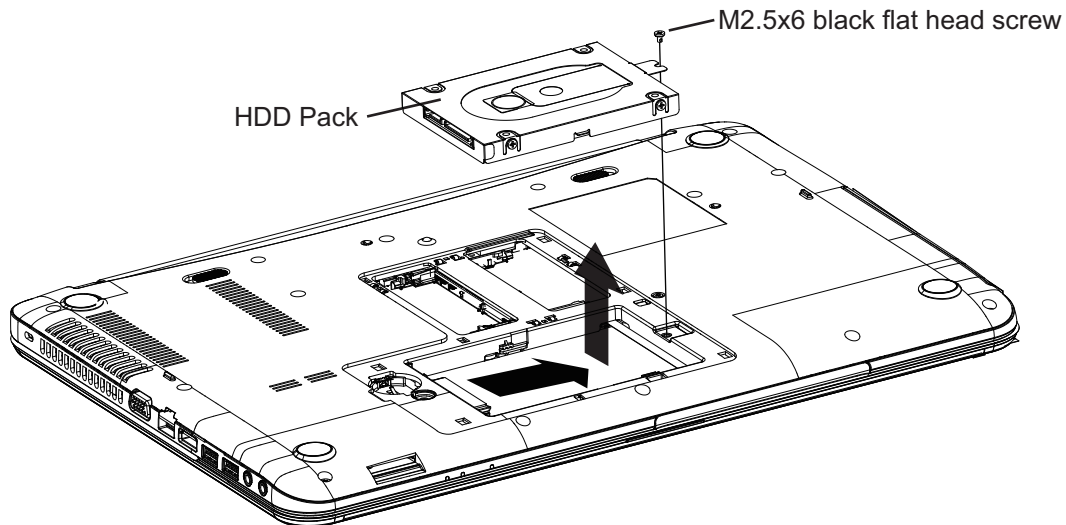

Figure 4-4 Removing the HDD pack

**NOTE:** Do not disassemble the HDD pack when it is working normally. Disassemble or replace the HDD pack only if it fails.

4. Place the HDD pack on a flat surface (such as a desk), and remove the four M3x3.5 black flat head screws.
5. Place the HDD pack on a flat surface (such as a desk), and remove the chassis.

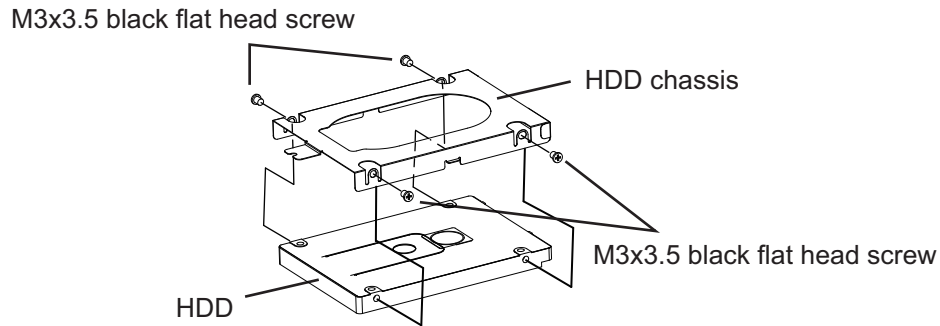

Figure 4-5 Removing the HDD chassis

**CAUTION:** Do not apply pressure to the top or bottom of the drive.

### Installing the HDD

Install the HDD according to the following procedures and Figures 4-4 and 4-5.

**CAUTION:** To avoid damage, always hold the HDD only by its sides.

1. Attach the HDD chassis.
2. Secure the HDD and its chassis with the four M3x3.5 black flat head screws.

**CAUTION:** To prevent the HDD bracket from being distorted when installing the HDD pack into the computer, do not press the center of the HDD pack. Always hold the HDD pack by its sides.

3. Install the HDD pack into the correct position in the computer. Connect the HDD pack to the computer, holding the HDD pack by its sides.
4. Secure the M2.5x6 black flat head screw securing the HDD pack.
5. Secure the memory HDD cover by tightening the HDD/Memory cover screw.

## 4.5 ODD Bay Module

### Removing the ODD Bay Module

**NOTE:** The installation and removal procedures are the same for all the modules that can be installed in the ODD bay. See the appropriate sections for the disassembly procedures of specific modules.

Remove the ODD Bay Module according to the following procedures and Figure 4-6.

1. Turn the computer upside down.
2. Remove the M2x3 black flat head screw.
3. Push out on the ODD Bay Module in the direction of the arrow.

**CAUTION:** Handle the ODD Bay Module carefully it can become hot during operation.

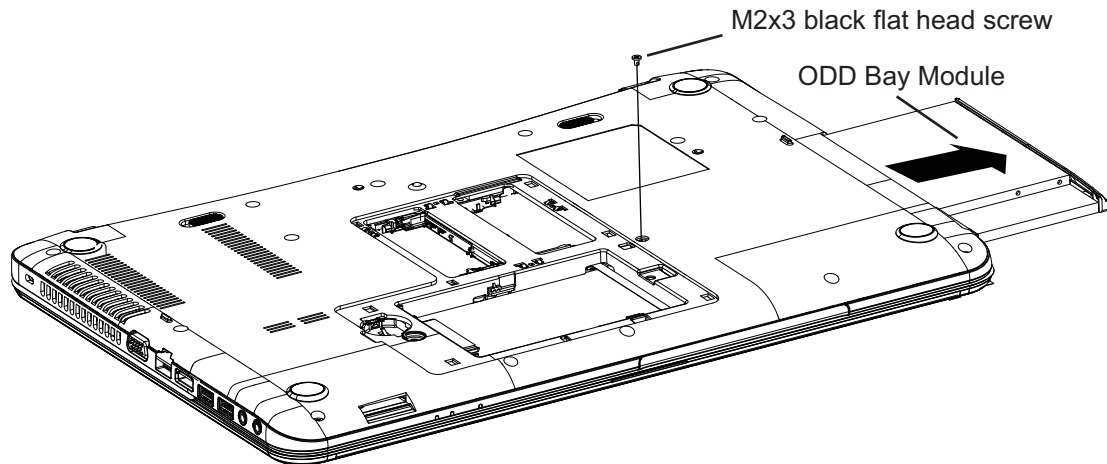

Figure 4-6 Removing the ODD Bay Module

**Installing the ODD Bay Module**

Install the ODD Bay Module according to the following procedures and Figure 4-6.

1. Place the ODD Bay Module in the correct position and slide it in.
2. Push it in until it clicks into place.
3. Secure the ODD Bay Module with one M2x3 whit flat head screw.

### Disassembling the ODD Drive

**NOTE:** Do not disassemble the ODD Drive when it is working normally. Disassemble or replace the ODD Drive only if it fails.

Disassemble the ODD Drive according to the following procedures and Figure 4-7.

1. Remove two M2x3 black flat head screws.
2. Remove the bracket.
3. Remove the ODD bezel by twist the bezel in clockwise direction.

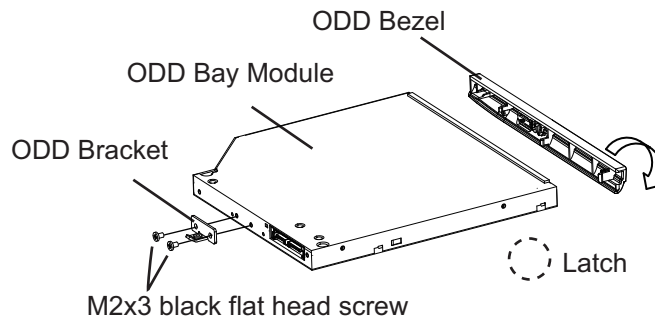

Figure 4-7 Removing the bracket from the ODD drive

### Assembling the ODD Drive

Assemble the ODD Drive according to the following procedures and Figure 4-7.

1. Seat the bracket and secure it with two M2x3 black flat head screws.
2. Reinstall the ODD bezel.

## 4.6 Keyboard

### Removing Keyboard

Remove the Keyboard according to the following procedures and Figure 4-8.

1. Insert the tool into the gap between Keyboard and top case, so let keyboard corner pops up carefully.
2. Release the following 15 latches on the Keyboard, in that order:
  - Seven latches on the bottom which is near touchpad.  
(The leftmost latch first, by the Sequence to the rightmost.)
  - One latch on right side and the pull the NUT, then one latch on left sides.
  - Six latches on the front side.
3. Disconnect the keyboard cable from CN250 on the system board.
4. Remove the Keyboard.

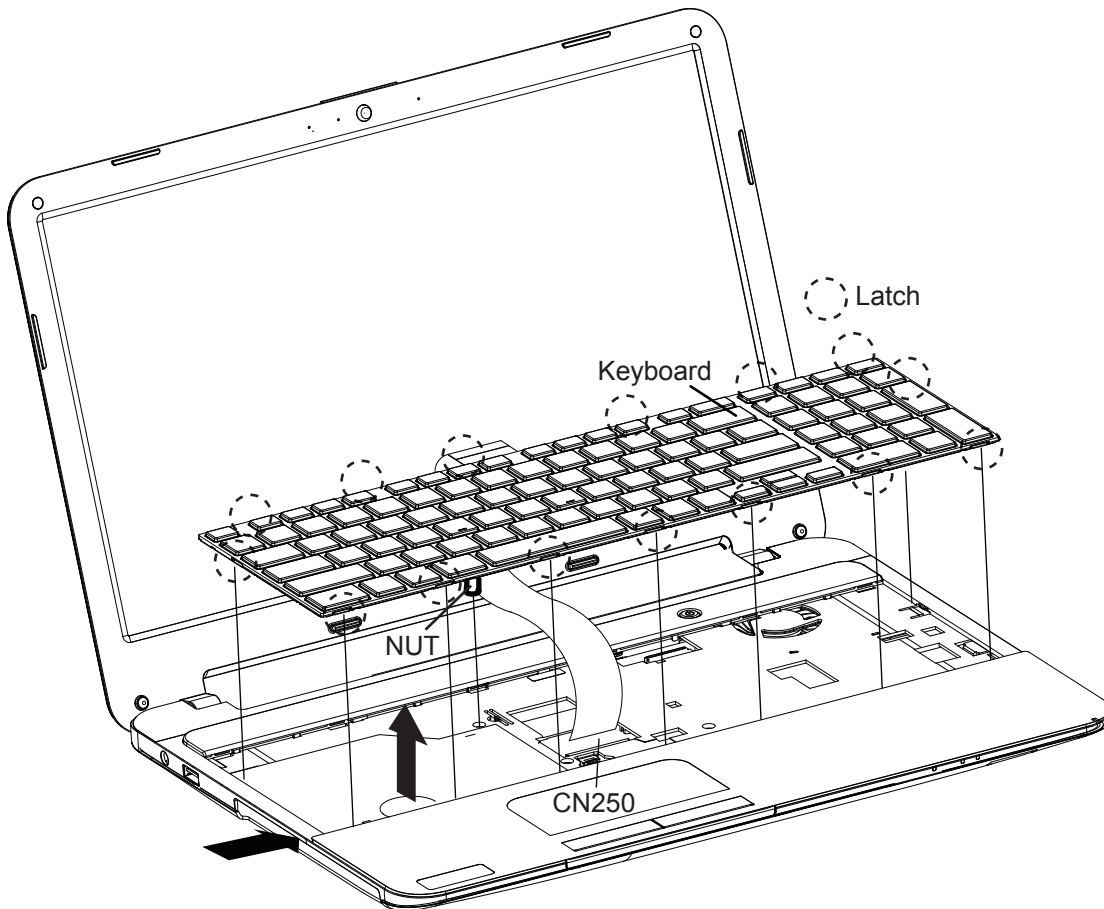

Figure 4-8 Removing the Keyboard



*NOTE: In case of Keyboard is difficult to remove, please utilize proper tool to release latch instead of pulling the Keyboard out violently.*

**Installing the Keyboard**

Install the Keyboard according to the following procedures and Figure 4-8.

1. Connect the Keyboard cable to CN250 on the system board.
2. Place the keyboard in the correct position and secure the following 15 latches, in that order:
  - One latch on right side and one latch on left sides.
  - Six latches on the front side.
  
  - Press located NUT to fix at top support.
  
  - Seven latches on the bottom which is near touchpad.

## 4.7 Wireless LAN Card

### Removing the Wireless LAN Card

Remove the wireless LAN Card according to the following procedures and Figures 4-9, 4-10 and 4-11.

**CAUTION:** Do not touch the connectors on the Wireless LAN Card and in the computer with your bare hands. Wireless LAN Cards can fail if they are contaminated with sweat, natural oils, etc. from your hands.

1. Turn the computer right side up and remove four M2.5x6 black flat head screws.

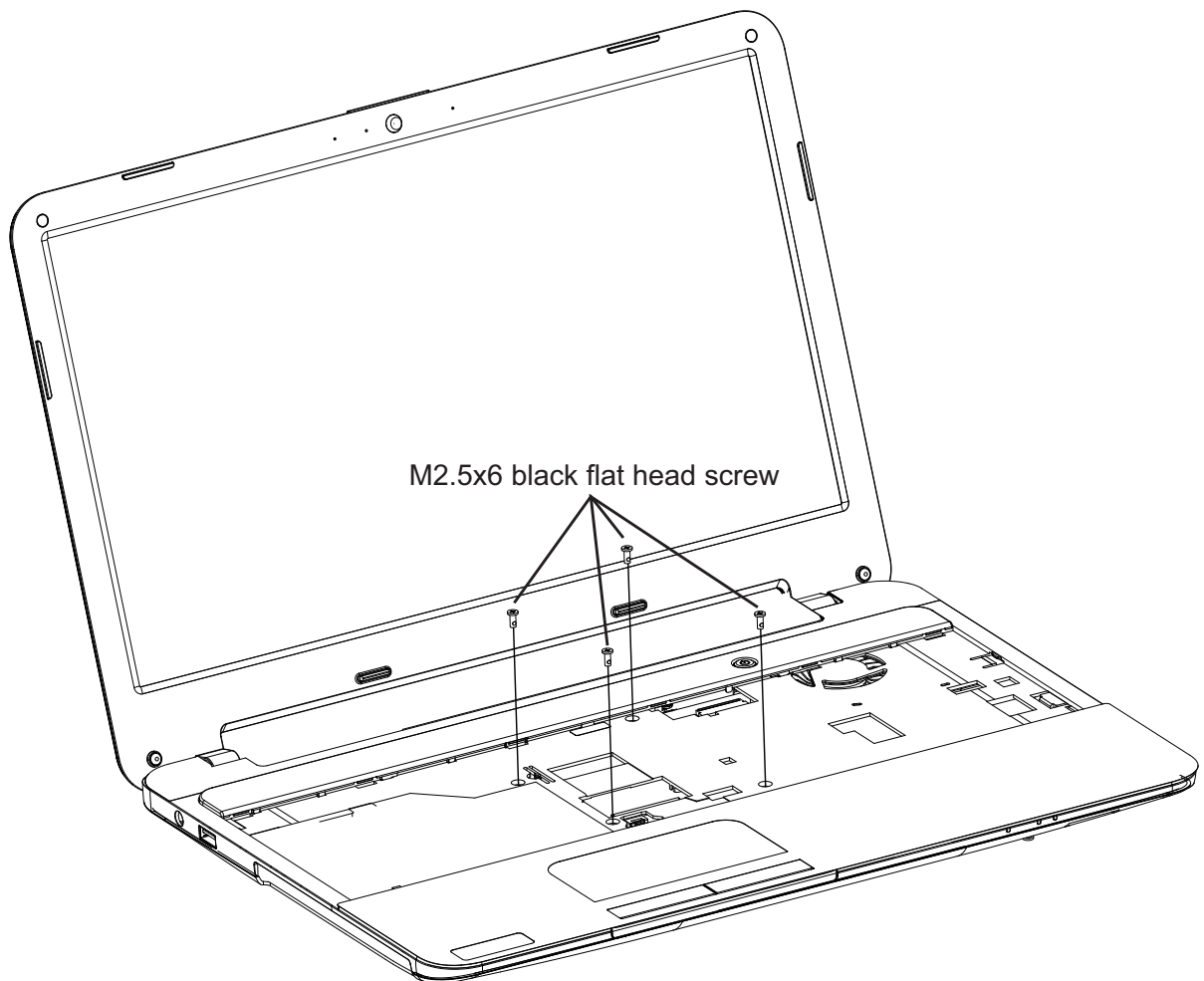

Figure 4-9 Removing the screws on the top cover

2. Turn the computer upside down and remove fourteen M2.5x6 black flat head screws securing the bottom cover.
3. Release 11 latches on the bottom cover

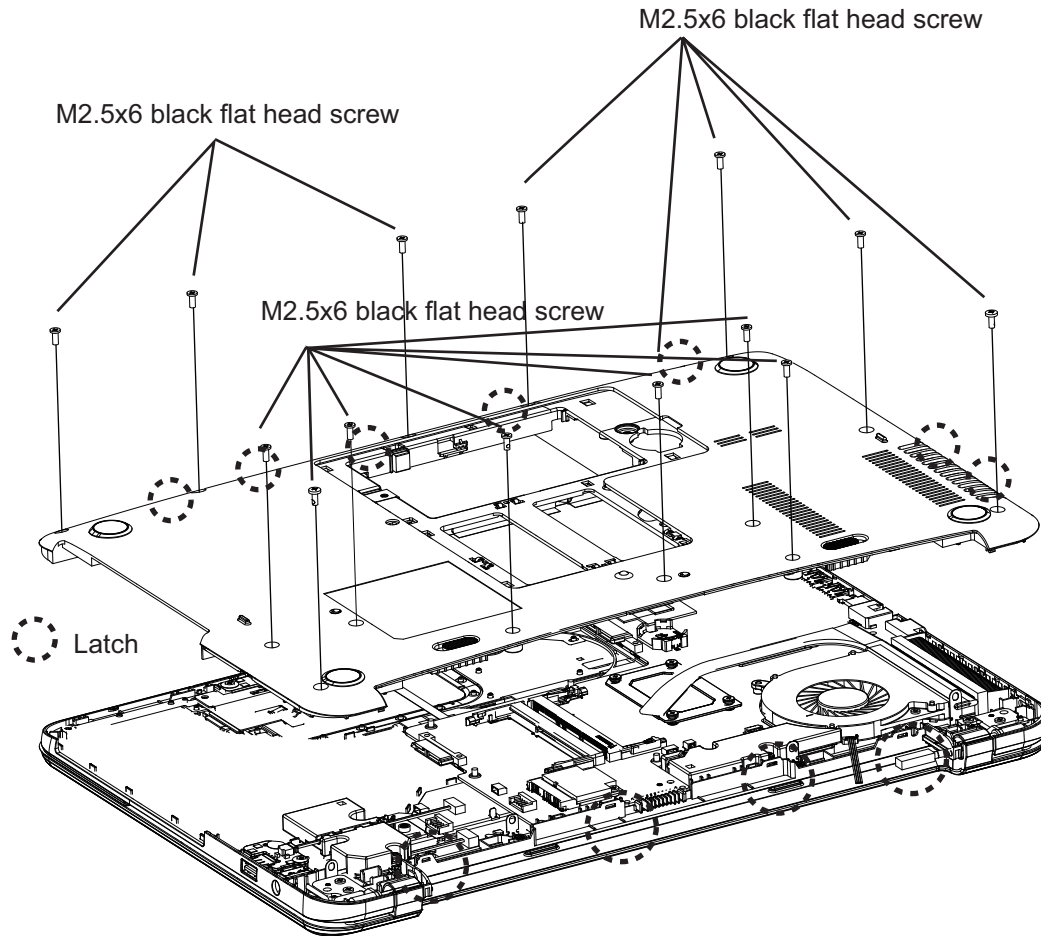

Figure 4-10 Removing the bottom cover

4. Disconnect the two antenna cables with tweezers.
5. Remove one M2x2 black flat head screw securing the Wireless LAN Card.
6. Pull the Wireless LAN Card up from CN1300 on the system board and out at an angle.

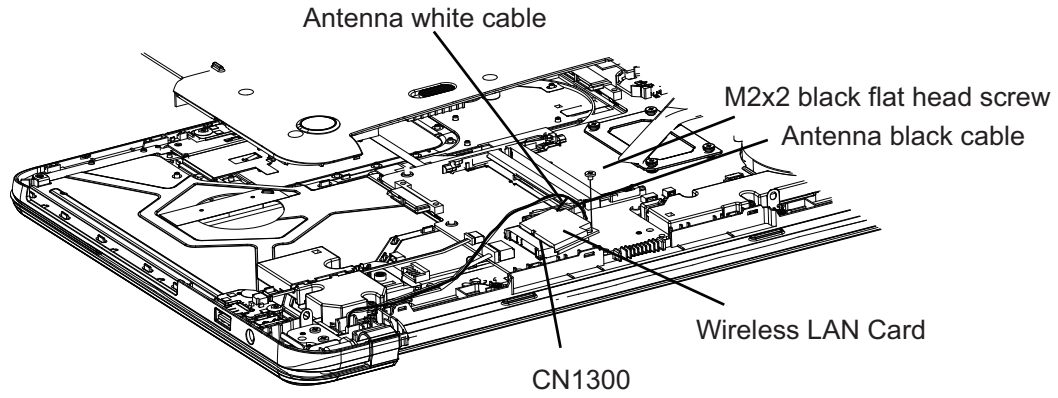

Figure 4-11 Removing the wireless LAN Card

### Installing the Wireless LAN Card

Install the Wireless LAN Card according to the following procedures and Figures 4-9, 4-10 and 4-11.

1. Insert the Wireless LAN Card into the CN1300 an angle of 45 degrees.
2. Press down on the Wireless LAN Card to secure it with one M2x2 black flat head screw.
3. Connect the two antenna cables by pressing them firmly into place.

*CAUTION: Do not touch the connectors on the Wireless LAN Card and in the computer with your bare hands. Wireless LAN Cards can fail if they are contaminated with sweat, natural oils, etc. from your hands.*

## 4.8 CPU Cooling Module and Fan

**CAUTION:** When removing the CPU Cooling Module, keep the following in mind:  
The CPU Cooling Module can become very hot during operation. Be sure to let it cool down before starting the repair work.  
Do not touch or cause damage to the fan in the CPU Cooling Module.

### Remove the CPU Cooling Module and Fan

Remove the CPU Cooling Module and Fan according to the following procedures and Figures 4-12 and 4-13.

1. Remove the fan cable from CN4300 on system board.
2. Remove two M2x3.5 white flat head screws on the Fan.
3. Remove the Fan.
4. Remove four screws as the order from 4-3-2-1 shown on the CPU Cooling Module.
5. Remove the CPU Cooling Module.

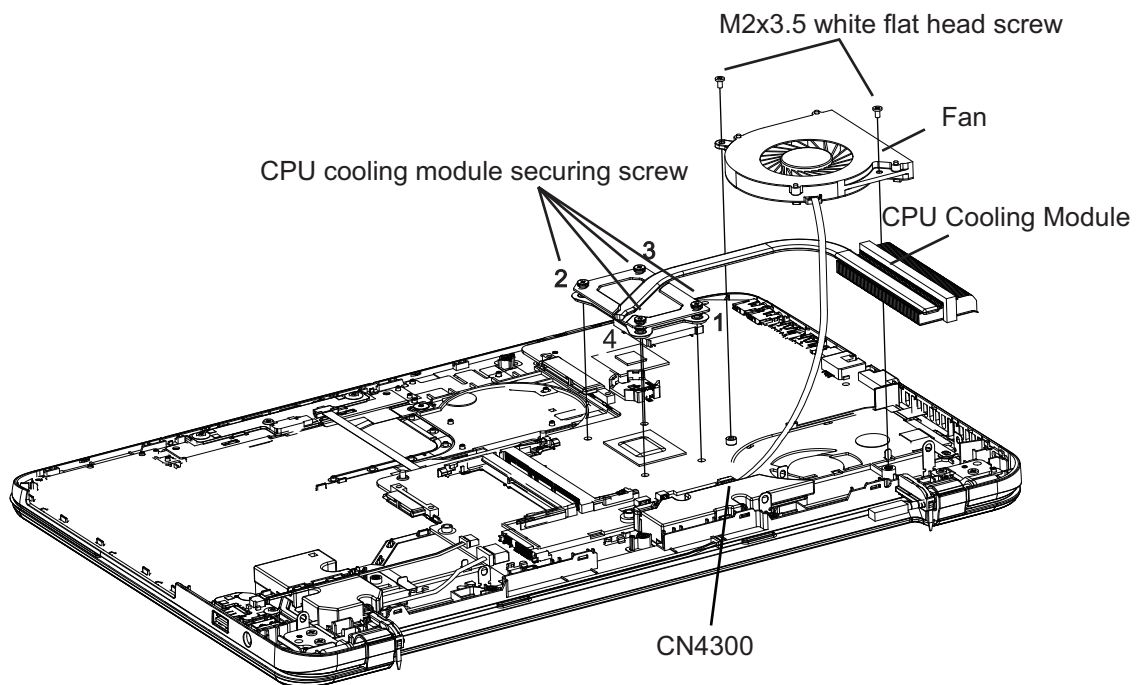

Figure 4-12 Removing the CPU Cooling Module and Fan



*Figure 4-13 Applying silicon grease*



### Installing the CPU Cooling Module and Fan

Install the CPU Cooling Module and Fan according to the following procedures and Figures 4-12 and 4-13.

*CAUTION: When installing the CPU Cooling Module, keep the following in mind:*

- 1. Be sure to confirm the correct position for the module.*
- 2. Secure the relevant screws on the main board according to the number sequence sealed on the heat sink module.*

*NOTE: Apply silicon grease with a special syringe to cover the surface of the CPU chip completely.*

1. Check the silicon grease on the CPU or the CPU Cooling Module,
  - If silicon grease is already applied to the new CPU Cooling Module completely, check that grease on the CPU needs to be wiped it off with a cloth.
  - If silicon grease is already applied to the CPU and CPU Cooling Module but not enough for cover the surface,, wipe it off with a cloth.By using a special syringe, apply silicon grease G7762 to the CPU chip center so that the entire CPU chip is covered with the grease G7762.
1. Install the CPU Cooling Module into the correct position on the system board.
2. Securing CPU Cooling Module with four screws as the order from 1-2-3-4 shown on the CPU Cooling Module.
3. Place the Fan in the correct position and secure it with two M2x3.5 white flat head screws.
4. Connect the fan cable to CN4300 on the system board.

## 4.9 System Board

### Removing the System Board

**NOTE:** Be careful of the eject button for the PC card. It can be damaged when removing the board. Make sure it is securely installed.

Remove the System Board according to the following procedures and Figures 4-14 and 4-15.

1. Turn the computer right side up.
2. Disconnect LCD cable from CN3000 and Touch Pad Board cable from CN281.

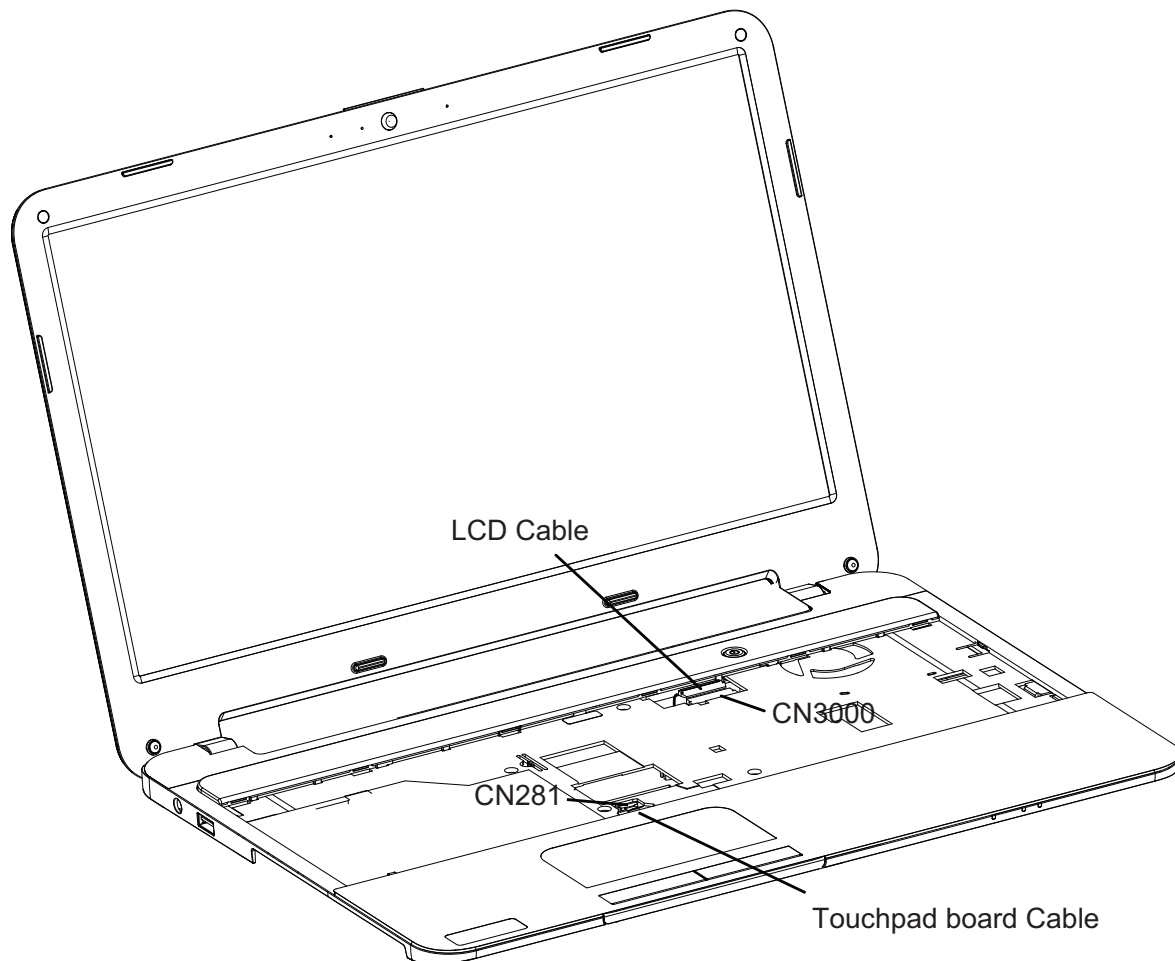

Figure 4-14 Removing the cables on System Board

3. Turn the computer upside down and disconnect the following cable from the connector on the bottom of System Board:
  - DC-IN cable from CN6000.
  - USB board cable from CN2002.
  - Power board cable from CN200
  - Speaker cable from CN600
4. Release two M2x3 black flat head screws securing the System Board.
5. Remove the System Board.

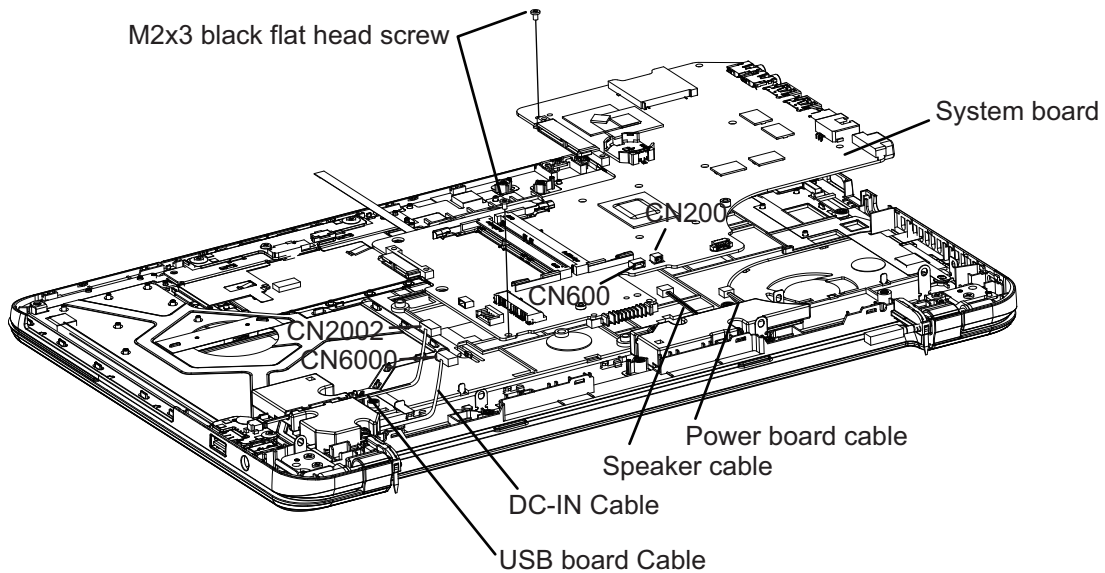

Figure 4-15 Removing the System Board

### Installing the System Board

Install the System Board according to the following procedures and Figures 4-14 and 4-15.

**NOTE:**

*Be careful of the eject button for the PC card. It can be damaged when installing the system board. Make sure it is pushed in.*

1. Connect LCD cable from CN3000 and touch pad board cable from CN281.
2. Seat the System Board in the correct position. Avoid to press the power board cable.
3. Secure the System Board with two M2x3 black flat head screws.
4. Connect the following cable from the connector on the bottom of System Board:
  - DC-IN cable from CN6000.
  - USB board cable from CN2002.
  - Power board cable from CN200.
  - Speaker cable from CN600.

## 4.10 LCD Module Assembly

### Removing the LCD Module Assembly

Remove the LCD Module Assembly according to the following procedures and Figure 4-16.

1. Released the LCD cable and wireless antenna cables from the rubber on the top cover.
2. Open the LCD Module Assembly at an angle of 90 degrees.
3. Turn the computer upside down.
4. Remove four M2.5x5 black flat head screws securing the LCD Module Assembly with the top cover.
5. Remove the LCD Module Assembly.

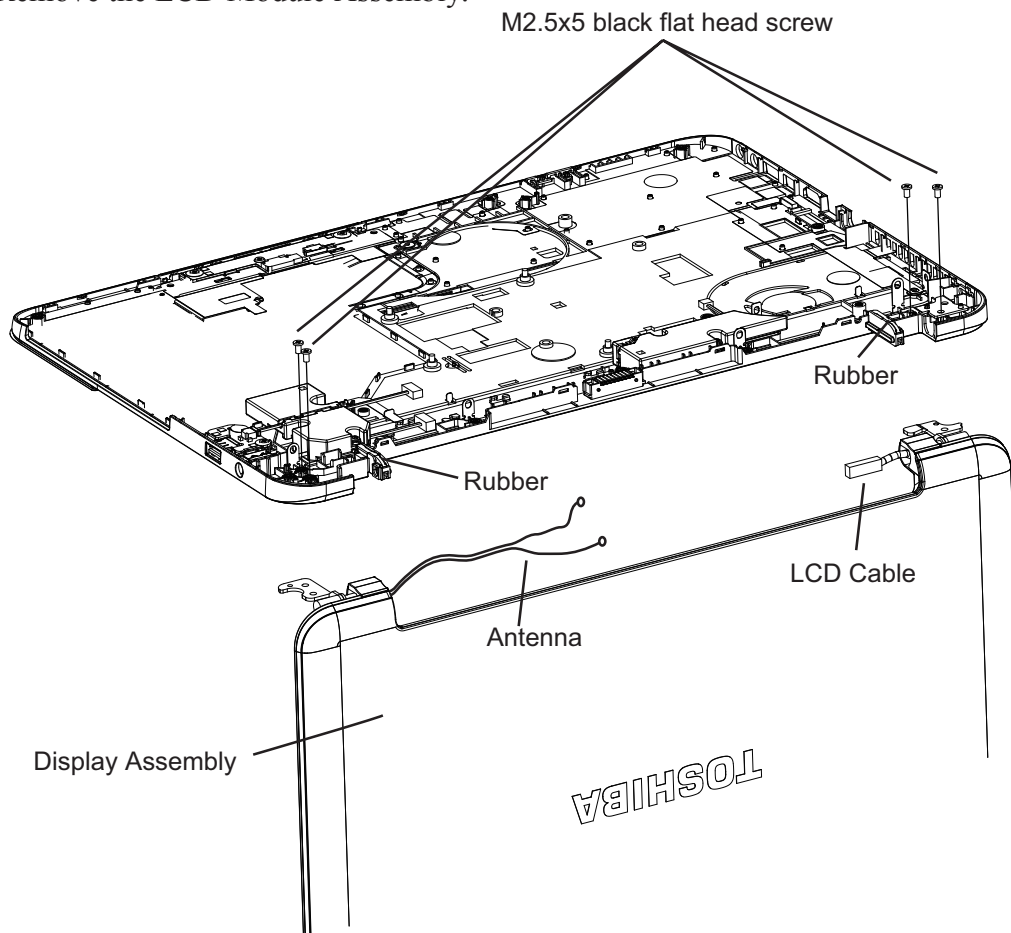

Figure 4-16 Removing the display assembly

**Installing the LCD Module Assembly**

Install the LCD Module Assembly according to the following procedures and Figure 4-16.

1. Place the LCD Module Assembly in the correct position.
2. Place the LCD cable and wireless antenna cables into the ditch and push the rubber in.
3. Secure the LCD Module Assembly with four M2.5x5 black flat head screws.
4. Close the LCD Module Assembly.

## 4.11 LCD Module Mask

### Remove the LCD Module Mask

Disassemble the LCD Module Mask according to the following procedures and Figure 4-17.

1. Peel off two seal tapes and two rubber tapes.
2. Remove four M2.5x4 black flat head screws securing the LCD Module Mask.
3. Insert your finger between the edge of LCD Module Mask and the LED panel by twist in correct indication to release the latch as steps from 1 to 4.
4. Remove the LCD Module Mask while unlatching the LCD Module Mask.

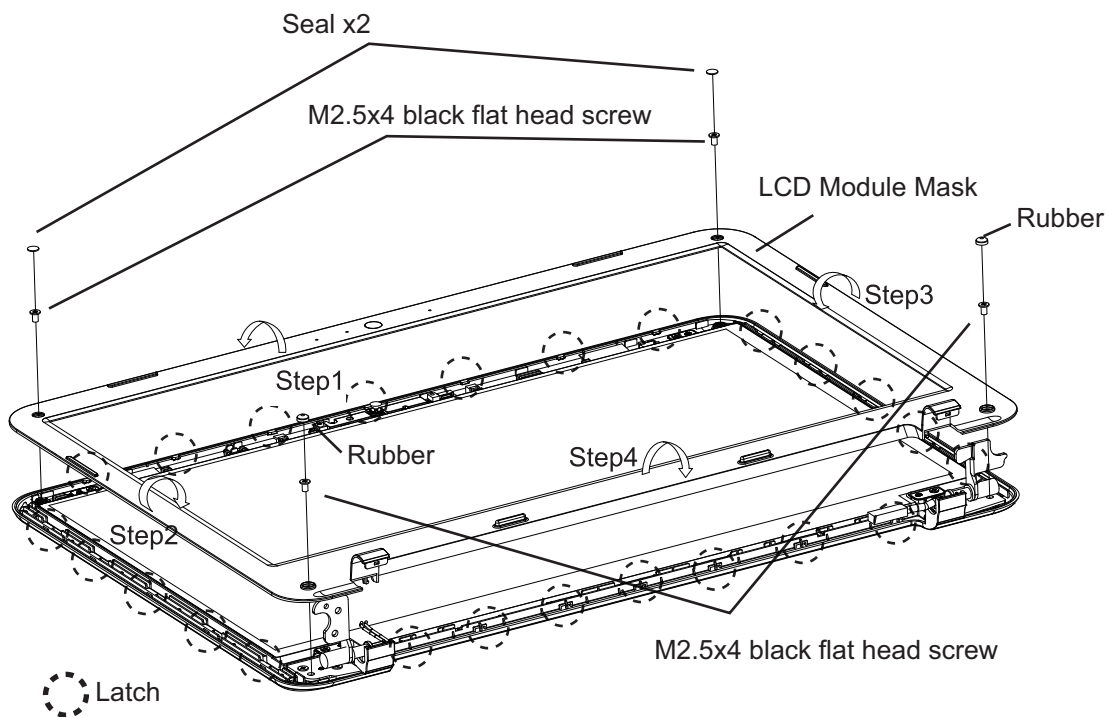

Figure 4-17 Removing the LCD Module Mask

**Installing the LCD Module Mask**

Install the LCD Module Mask according to the following procedures and Figure 4-17.

1. Install the LCD Module Mask and lock the latches

**NOTE:** *When installing the LCD Module Mask, ensure there is no gap between the LCD Module Mask and the LCD module cover.*

2. Secure the LCD Module Mask with four 2.5x4 black flat head screws and stick two seal tapes and two rubber tapes.



## 4.12 LED Panel

**NOTE:** ICs are fragile. Use extreme care not to apply pressure to the ICs along the edges of the LCD module.

**NOTE:** Dispose of used LED Panel (fluorescent (FL) tubes) as required by local ordinances or regulations.

**NOTE:** The LCD cable must be carefully peeled away before disconnecting it from the module.

### Removing the LED Panel

Remove the LED Panel according to the following procedures and Figures 4-18 and 4-19.

1. Remove three M2.5x3.5 white flat head screws on each side securing the LCD module hinges.
2. Remove two M2x3 black flat head screws on each side securing the LED Panel.
3. Remove the LED panel bracket.

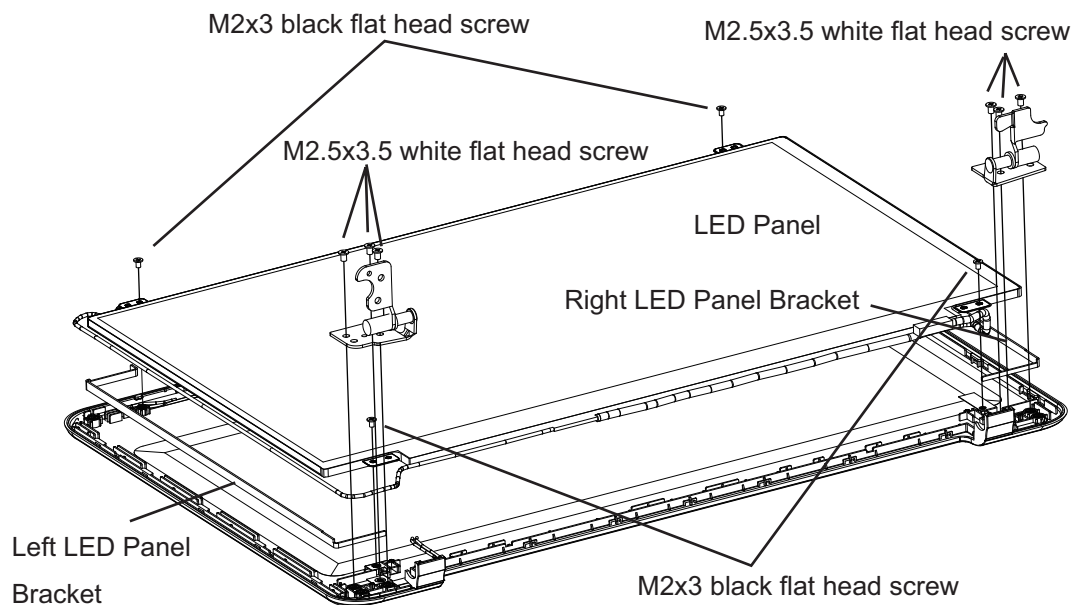
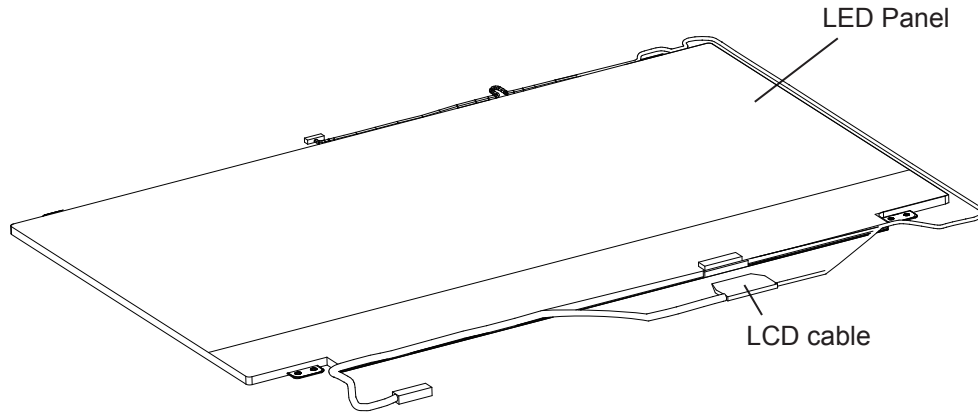

Figure 4-18 Removing the LCD module hinges, LED Panel and LED panel brackets

4. Turn the LED Panel upside down. Be sure to place it on a cushioned surface such as a foam pad.
5. Remove the tape and LCD cable connector. Then disconnect the LCD cable.



*Figure 4-19 Removing the LCD cable*

### Installing the LED Panel

**NOTE:** LCD/FL cable must be carefully peeled away before disconnecting it from the module.

Install the LED Panel according to the following procedures and Figures 4-18 and 4-19.

1. Turn the LED Panel upside down.
2. Connect the LCD cable to the LED panel connector.
3. Place the LED panel bracket in the correct position
4. Place the LED Panel in the correct position and secure it with two M2x3 black flat head screws on each side.
5. Place the LCD module hinges in the correct position and secure it with three M2.5x3.5 white flat head screws on LCD module cover..

**CAUTION:** When installing the LCD module, please follow below instruction:

When plug in LCD/FL cable into LED panel connector, need to plug horizontally. For Sharp panel, if LCD/FL cable connector is not plugged horizontally, it may be damaged.

## 4.13 CCD Module

### Removing the CCD Module

Remove the CCD Module according to the following procedures and Figure 4-20

1. Lift the CCD Module from the LCD module cover.
2. Disconnect LCD cable from CCD Module connector.

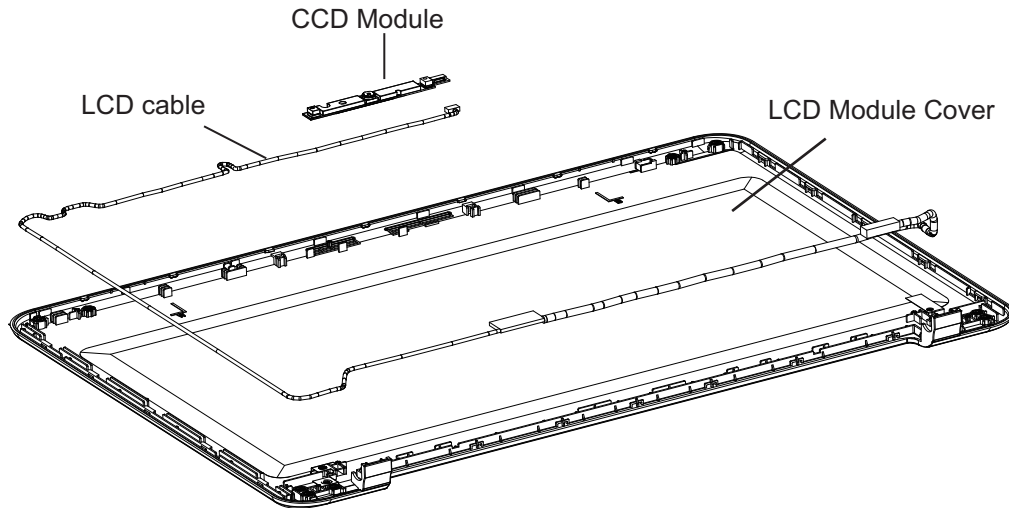

Figure 4-20 Removing the CCD Module

### **Installing the CCD Board**

Install the CCD Board according to the following procedures and Figure 4-20.

1. Connect LCD cable to CCD module connector.
2. Seat the CCD Module in the correct position.

## 4.14 Speakers

### Removing the Speakers

Remove the Speakers according to the following procedures and Figure 4-21.

1. Remove one M2x3 black flat head screw securing the left Speaker.
2. Remove one M2x3 black flat head screw securing the right Speaker.
3. Remove the left and right Speakers.

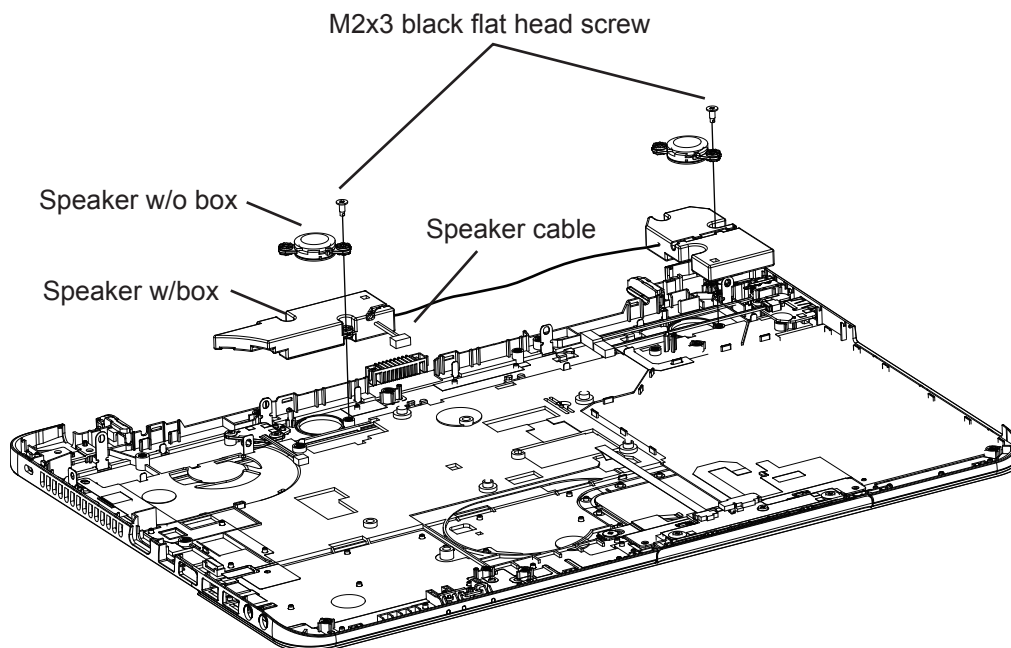

*Figure 4-21 Removing the speakers*

### Installing the Speakers

Install the speakers according to the following procedures and Figure 4-21.

1. Seat the left and right Speakers in the correct position.
2. Route the speaker cable in the wire guide.
3. Secure the left speaker with one M2x3 black flat head screw.
4. Secure the right speaker with one M2x3 black flat head screw.

## 4.15 Power Board, USB Board and DC-IN harness

### Removing the Power Board, USB Board and DC-IN Harness

Remove the Power Board, USB Board and DC-IN Harness according to the following procedures and Figure 4-22.

1. Lift the USB cable and power board cable from the bottom case.
2. Release two M2x3 black flat head screws securing Power Board.
3. Remove the Power Board
4. Release one M2x3 black flat head screws securing USB Board
5. Remove the USB Board and DC-IN Harness.

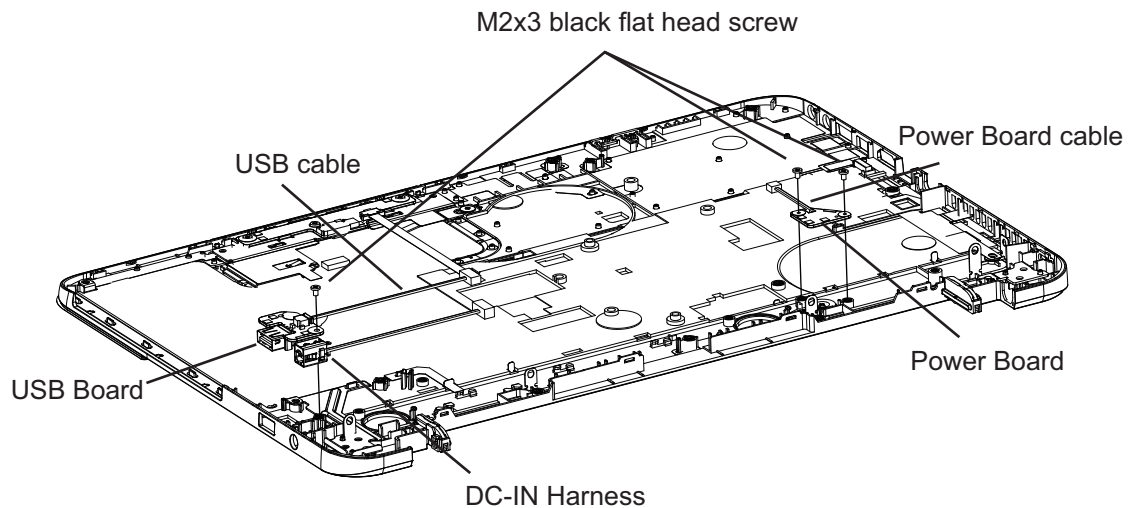

*Figure 4-22 Removing the Power Board, USB Board and DC-IN Harness*

### Installing the Power Board, USB Board and DC-IN Harness

Install the Power Board, USB Board and DC-IN Harness according to the following procedures and Figure 4-22.

1. Seat the Power Board, USB Board and DC-IN Harness in the correct position.
2. Route the cables in the wire guide and place DC-IN Harness in correct position.
3. Secure the Power Board with two M2x3 black flat head screws
4. Secure the USB Board with one M2x3 black flat head screw

## 4.16 Touchpad Board

### Removing the Touchpad Board

Remove the Touchpad Board according to the following procedures and Figure 4-23.

1. Release three M2x3 black flat head screws securing the Touchpad Board.
2. Remove the Touchpad Board.
3. Release one M2x2 white flat head screw securing the Touchpad Bracket.
4. Remove the Touchpad Bracket.
5. Disconnect the flat cable on the Touchpad board.

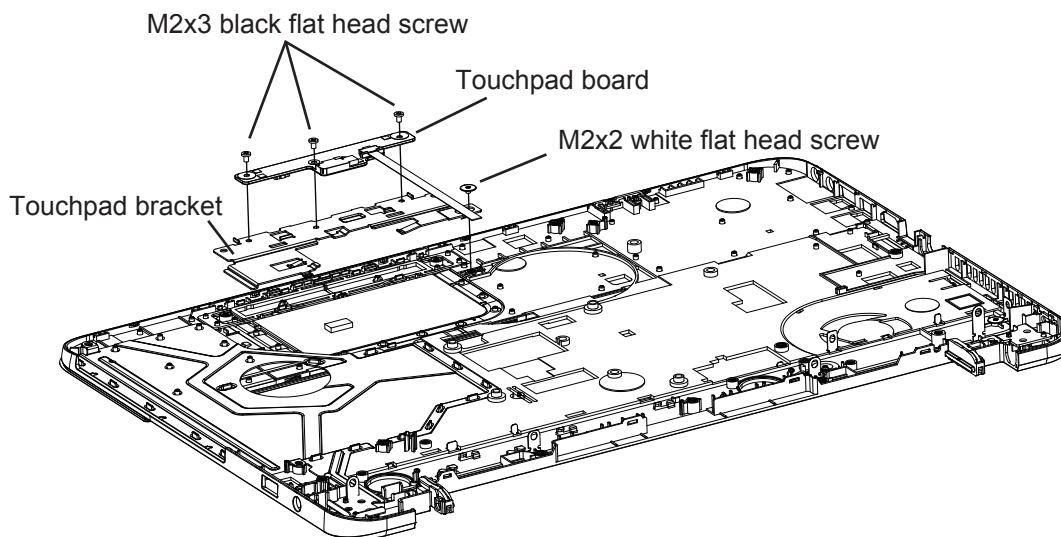

*Figure 4-23 Removing the Touchpad board*

### Installing the Touchpad board

Install the Touchpad board according to the following procedures and Figure 4-23.

1. Seat the Touchpad bracket in the correct position.
2. Secure Touchpad bracket with one M2x2 white flat head screw.
3. Seat the Touchpad board in the correct position.
4. Secure Touchpad bracket with three M2x3 black flat head screws.
5. Connect the flat cable on the Touchpad Board.



---

# Appendices

---

## **Appendix Contents**

<b>Appendix A Handling the LCD Module</b> .....	<b>A-1</b>
<b>Appendix B Board Layout</b> .....	<b>B-1</b>
B.1 System Board Front View .....	B-1
B.2 System Board Back View.....	B-2
<b>Appendix C Keyboard Scan/Character Codes</b> .....	<b>C-1</b>
<b>Appendix D Key Layout</b> .....	<b>D-1</b>

---

## Appendix A Handling the LCD Module

---

### Precautions for handling the LCD module

The LCD module can be easily damaged during assembly or disassembly. Observe the following precautions when handling the LCD module:

1. When installing the LCD module in the LCD cover, be sure to seat it so that it is properly aligned and maximum visibility of the display is maintained.

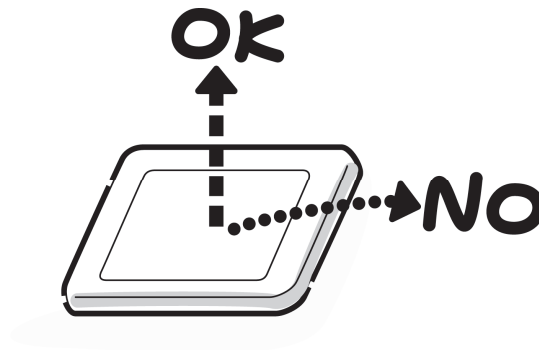

2. Be careful to align the four holes at the right side and left side of the LCD module with the corresponding holes in the LCD cover before securing the module with four screws. Do not force the module into place, because stress can affect its performance. Also, the panel's polarized surface is easily scarred, so be carefully when handling it.

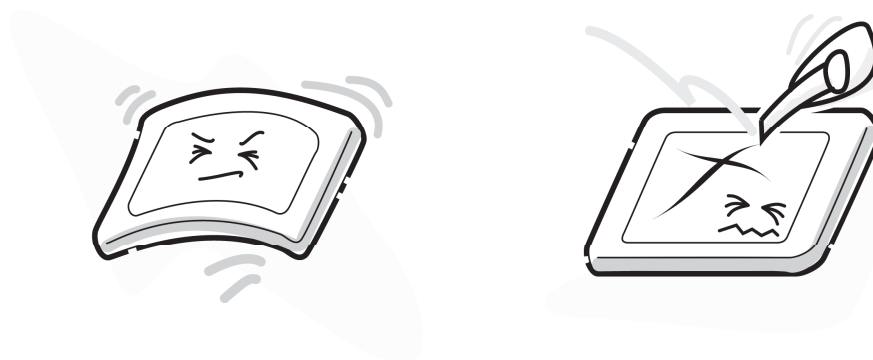

3. If the panel's surface gets dirty, wipe it with cotton or a soft cloth. If it is still dirty, try breathing on the surface to create a light condensate and wipe it again.

If the surface is very dirty, we recommend a CRT cleaning agent. Apply the agent to a cloth and then wipe the panel's surface. Do not apply cleanser directly to the panel. Also, never scratch the surface.



4. If water or other liquid is left on the panel's surface for a long period, it can change the screen's tint or stain it. Be sure to quickly wipe off any liquid.



5. Glass is used in the panel, so be careful not to drop it or let it strike a hard object, which could cause breakage or cracks.

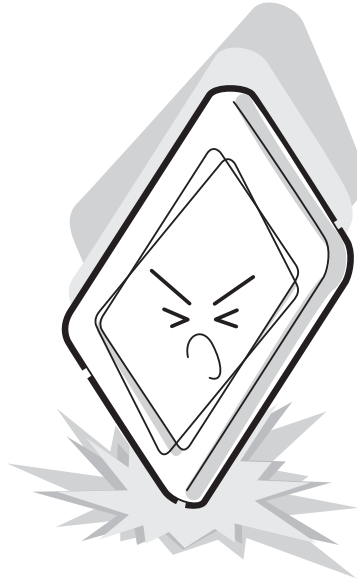

6. CMOS-LSI circuits are used in the module, so guard against damage from electrostatic discharge. Be sure to wear a wrist or ankle ground when handling the module.

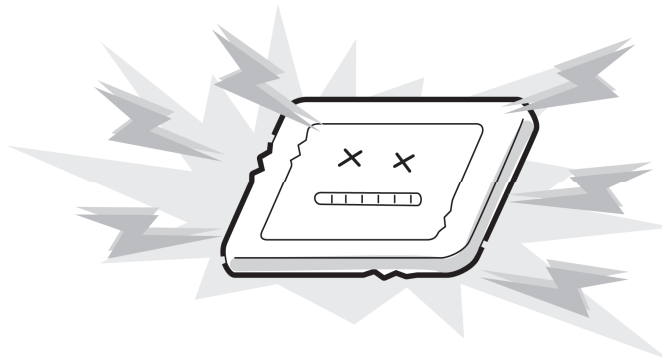

7. Do not expose the module to direct sunlight or strong ultraviolet rays for long periods.



8. Do not store the module at temperatures below specifications. Cold can cause the liquid crystals to freeze, lose their elasticity or otherwise suffer damage.

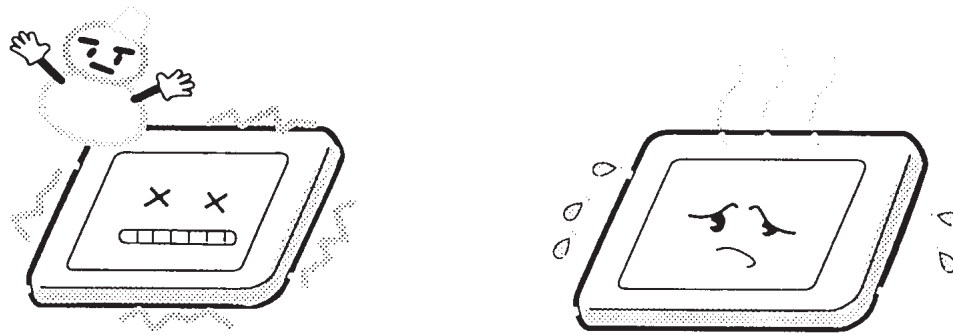

9. Do not disassemble the LCD module. Disassembly can cause malfunctions.

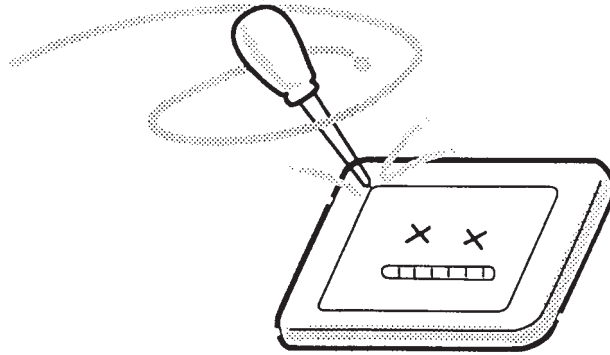

10. If you transport the module, do not use packing material that contains epoxy resin (amine) or silicon glue (alcohol or oxide). These materials can release gas that can damage the panel's polarization.

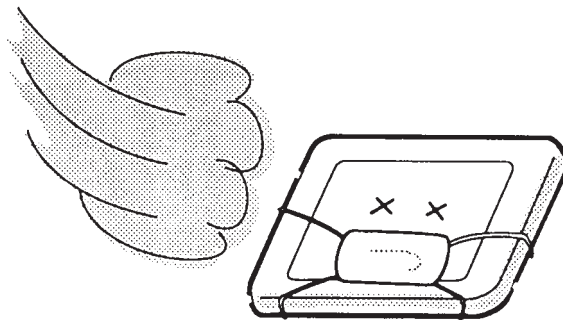

## Appendix B Board Layout

### B.1 System Board Front View

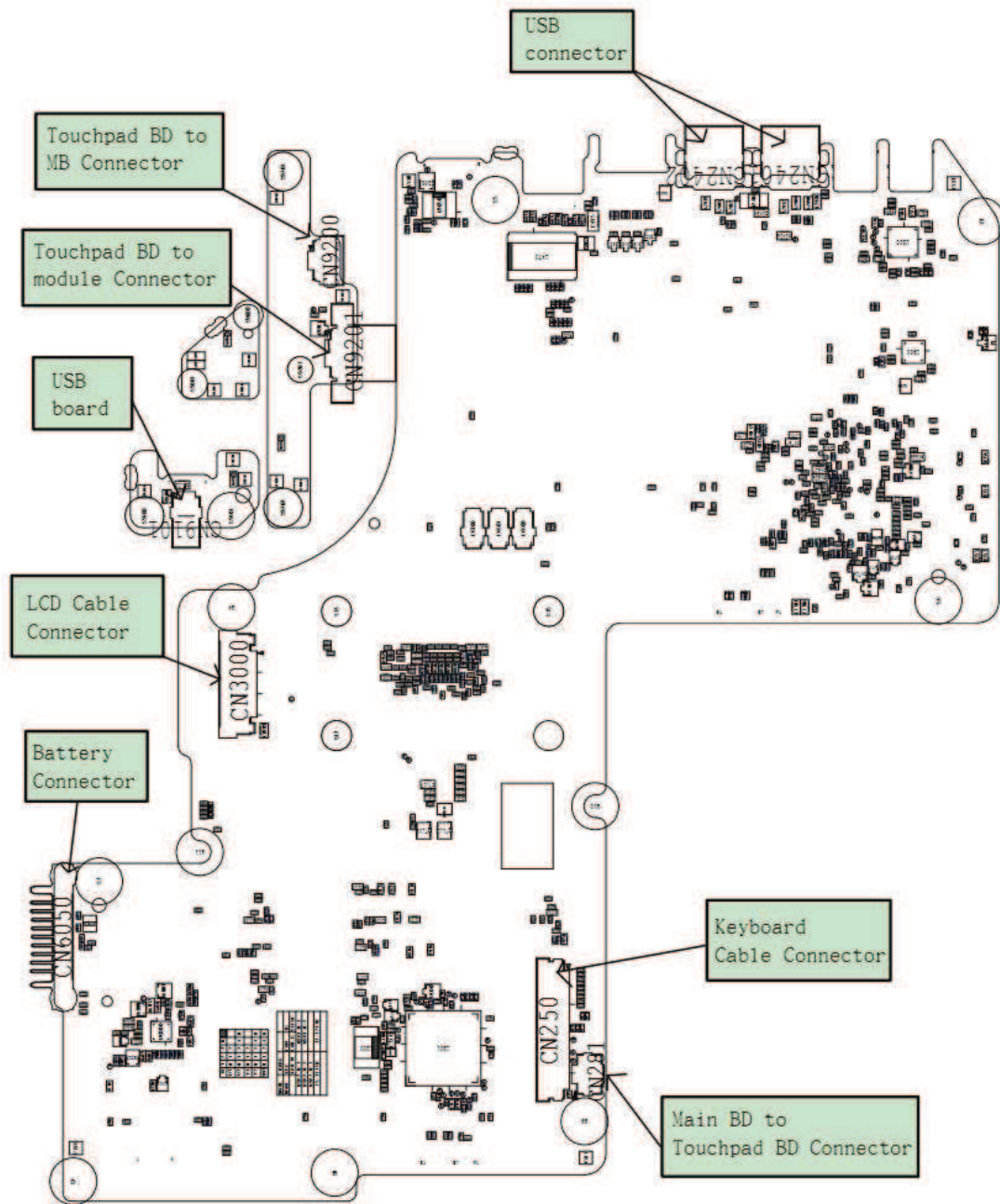

Figure B-1 Board Layout (Front)



## B.2 System Board Back View

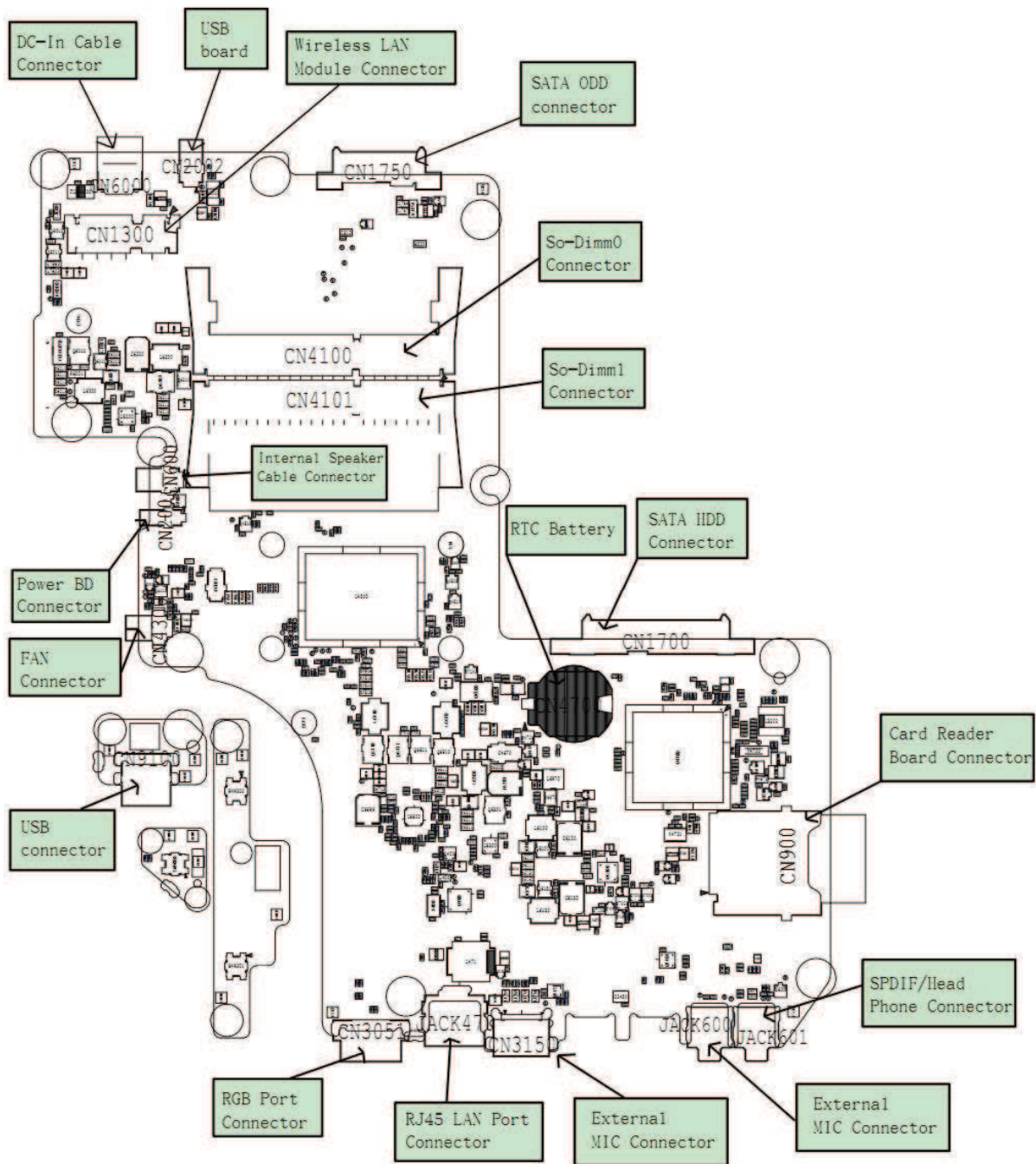

Figure B-2 Board Layout (Back)

**Appendix C Keyboard Scan/Character Codes**

*Table C-1 Scan Codes (set 1 and set 2) (1/4)*

Cap No.	Keytop	Code set 1		Code set 2			Note
		Make	Break	Make	Break		
01	' ~	29	A9	0E	F0	0E	
02	1 !	02	82	16	F0	16	
03	2 @	03	83	1E	F0	1E	
04	3 #	04	84	26	F0	26	
05	4 \$	05	85	25	F0	25	
06	5 %	06	86	2E	F0	2E	
07	6 ^	07	87	36	F0	36	
08	7 &	08	88	3D	F0	3D	*2
09	8 *	09	89	3E	F0	3E	*2
10	9 (	0A	8A	46	F0	46	*2
11	0 )	0B	8B	45	F0	45	*2
12	- _	0C	8C	4E	F0	4E	
13	= +	0D	8D	55	F0	55	
14				7D	F0	7D	
15	BkSp	0E	8E	66	F0	66	
16	Tab	0F	8F	0D	F0	0D	
17	Q	10	90	15	F0	15	
18	W	11	91	1D	F0	1D	
19	E	12	92	24	F0	24	
20	R	13	93	2D	F0	2D	
21	T	14	94	2C	F0	2C	
22	Y	15	95	35	F0	35	
23	U	16	96	3C	F0	3C	*2
24	I	17	97	43	F0	43	*2
25	O	18	98	44	F0	44	*2
26	P	19	99	4D	F0	4D	*2
27	[ {	1A	9A	54	F0	54	
28	] }	1B	9B	5B	F0	5B	

Table C-1 Scan Codes (set 1 and set 2) (2/4)

Cap No.	Keytop	Code set 1		Code set 2		Note	
		Make	Break	Make	Break		
29	\	2B	AB	5D	F0	5D	*5
30	Caps Lock	3A	BA	58	F0	58	
31	A	1E	9E	1C	F0	1C	
32	S	1F	9F	1B	F0	1B	
33	D	20	A0	23	F0	23	
34	F	21	A1	2B	F0	2B	
35	G	22	A2	34	F0	34	
36	H	23	A3	33	F0	33	
37	J	24	A4	3B	F0	3B	*2
38	K	25	A5	42	F0	42	*2
39	L	26	A6	4B	F0	4B	*2
40	; :	27	A7	4C	F0	4C	*2
41	' "	28	A8	52	F0	52	
43	Enter	1C	9C	5A	F0	5A	*3
44	Shift (L)	2A	AA	12	F0	12	
45	No.102 key	56	D6	61	F0	61	
46	Z	2C	AC	1A	F0	1A	
47	X	2D	AD	22	F0	22	
48	C	2E	AE	21	F0	21	
49	V	2F	AF	2A	F0	2A	
50	B	30	B0	32	F0	32	
51	N	31	B1	31	F0	31	
52	M	32	B2	3A	F0	3A	*2
53	, <	33	B3	41	F0	41	*2
54	. >	34	B4	49	F0	49	*2
55	/ ?	35	B5	4A	F0	4A	*2
56	_			73	F0	73	
57	Shift (R)	36	B6	59	F0	59	

Table C-1 Scan Codes (set 1 and set 2) (3/4)

Cap No.	Keytop	Code set 1		Code set 2			Note
		Make	Break	Make	Break		
58	Ctrl	1D	9D	14	F0	14	*3
60	Alt (L)	38	B8	11	F0	11	*3
61	Space	39	B9	29	F0	29	
62	ALT (R)	E0 38	E0 B8	E0 11	E0 F0	11	
75	Ins	E0 52	E0 D2	E0 70	E0 F0	70	*1
76	Del	E0 53	E0 D3	E0 71	E0 F0	71	*1
79	←	E0 4B	E0 CB	E0 6B	E0 F0	6B	*1
80	Home	E0 47	E0 C7	E0 6C	E0 F0	6C	*1
81	End	E0 4F	E0 CF	E0 69	E0 F0	69	*1
83	↑	E0 48	E0 C8	E0 75	E0 F0	75	*1
84	↓	E0 50	E0 D0	E0 72	E0 F0	72	*1
85	PgUp	E0 49	E0 C9	E0 7D	E0 F0	7D	*1
86	PgDn	E0 51	E0 D1	E0 7A	E0 F0	7A	*1
89	→	E0 4D	E0 CD	E0 74	E0 F0	74	*1
110	Esc	01	81	76	F0	76	
112	F1	3B	BB	05	F0	05	
113	F2	3C	BC	06	F0	06	
114	F3	3D	BD	04	F0	04	
115	F4	3E	BE	0C	F0	0C	
116	F5	3F	BF	03	F0	03	
117	F6	40	C0	0B	F0	0B	
118	F7	41	C1	83	F0	83	
119	F8	42	C2	0A	F0	0A	
120	F9	43	C3	01	F0	01	
121	F10	44	C4	09	F0	09	*3

Table C-1 Scan Codes (set 1 and set 2) (4/4)

Cap No.	Keytop	Code set 1				Code set 2				Note
		Make		Break		Make		Break		
122	F11	57		D7		78		F0 78		*3
123	F12	58		D8		7		F0 7		*3
124	PrintSc	*6		*6		*6		*6		*6
126	Pause	*7		*7		*7		*7		*7
202	Fn	—		—		—		—		*4
203	Win	E0	5B	E0	DB	E0	1F	E0	F0 1F	
204	App	E0	5D	E0	DD	E0	2F	E0	F0 2F	
205	Kat/Hir					70		F0 70		*8
206	Hen					79		F0 79		*8
207	Muh					7B		F0 7B		*8

Notes:

1. \* Scan codes differ by mode.
2. \* Scan codes differ by overlay function.
3. \* Combination with the **Fn** key makes different codes.
4. \* **Fn** key does not generate a code by itself.
5. \* This key corresponds to key No. 42 in a 102-key model.
6. \* Refer to Table C-6, No. 124 key scan code.
7. \* Refer to Table C-7, No. 126 key scan code.
8. \* 205~207 are for JAPAN keyboard only

*Table C-2 Scan Codes with left Shift key*

Cap No.	Key top	Code set 1				Code set 2			
		Make		Break		Make		Break	
55	/	E0 AA E0 35	E0 B5 E0 2A	E0 F0 12 E0 4A	E0 F0 4A E0 12				
75	INS	E0 AA E0 52	E0 D2 E0 2A	E0 F0 12 E0 70	E0 F0 70 E0 12				
76	DEL	E0 AA E0 53	E0 D3 E0 2A	E0 F0 12 E0 71	E0 F0 71 E0 12				
79	←	E0 AA E0 4B	E0 CB E0 2A	E0 F0 12 E0 6B	E0 F0 6B E0 12				
80	Home	E0 AA E0 47	E0 C7 E0 2A	E0 F0 12 E0 6C	E0 F0 6C E0 12				
81	End	E0 AA E0 4F	E0 CF E0 2A	E0 F0 12 E0 69	E0 F0 69 E0 12				
83	↑	E0 AA E0 48	E0 C8 E0 2A	E0 F0 12 E0 75	E0 F0 75 E0 12				
84	↓	E0 AA E0 50	E0 D0 E0 2A	E0 F0 12 E0 72	E0 F0 72 E0 12				
85	PgUp	E0 AA E0 49	E0 C9 E0 2A	E0 F0 12 E0 7D	E0 F0 7D E0 12				
86	PgDn	E0 AA E0 51	E0 D1 E0 2A	E0 F0 12 E0 7A	E0 F0 7A E0 12				
89	→	E0 AA E0 4D	E0 CD E0 2A	E0 F0 12 E0 74	E0 F0 74 E0 12				
203	Win	E0 AA E0 5B	E0 DB E0 2A	E0 F0 12 E0 1F	E0 F0 1F E0 12				
204	App	E0 AA E0 5D	E0 DD E0 2A	E0 F0 12 E0 2F	E0 F0 2F E0 12				

**Note :** The table above shows scan codes with the left **Shift** key. In combination with the right **Shift** key, scan codes are changed as listed below:

	With left <b>Shift</b>	With right <b>Shift</b>
Set 1	E0 AA _____	E0 B6
	E0 2A _____	E0 36
Set 2	E0 F0 12 _____	E0 F0 59
	E0 12 _____	E0 59

Table C-3 Scan Codes in Numlock mode

Cap No.	Key top	Code set 1								Code set 2									
		Make				Break				Make				Break					
75	INS	E0	2A	E0	52	E0	D2	E0	AA	E0	12	E0	70	E0	F0	70	E0	F0	12
76	DEL	E0	2A	E0	53	E0	D3	E0	AA	E0	12	E0	71	E0	F0	71	E0	F0	12
79	←	E0	2A	E0	4B	E0	CB	E0	AA	E0	12	E0	6B	E0	F0	6B	E0	F0	12
80	Home	E0	2A	E0	47	E0	C7	E0	AA	E0	12	E0	6C	E0	F0	6C	E0	F0	12
81	End	E0	2A	E0	4F	E0	CF	E0	AA	E0	12	E0	69	E0	F0	69	E0	F0	12
83	↑	E0	2A	E0	48	E0	C8	E0	AA	E0	12	E0	75	E0	F0	75	E0	F0	12
84	↓	E0	2A	E0	50	E0	D0	E0	AA	E0	12	E0	72	E0	F0	72	E0	F0	12
85	PgUp	E0	2A	E0	49	E0	C9	E0	AA	E0	12	E0	7D	E0	F0	7D	E0	F0	12
86	PgDn	E0	2A	E0	51	E0	D1	E0	AA	E0	12	E0	7A	E0	F0	7A	E0	F0	12
89	→	E0	2A	E0	4D	E0	CD	E0	AA	E0	12	E0	74	E0	F0	74	E0	F0	12
203	Win	E0	2A	E0	5B	E0	DB	E0	AA	E0	12	E0	1F	E0	F0	1F	E0	F0	12
204	App	E0	2A	E0	5D	E0	DD	E0	AA	E0	12	E0	2F	E0	F0	2F	E0	F0	12

Table C-4 Scan Codes with Fn key

Cap No.	Keytop	Code set 1				Code set 2				
		Make		Break		Make		Break		
43	ENT	E0	1C	E0	9C	E0	5A	E0	F0	5A
58	CTRL	E0	1D	E0	9D	E0	14	E0	F0	14
60	LALT	E0	38	E0	B8	E0	11	E0	F0	11
121	ARROW		45		C5		77		F0	77
122	NUMERIC		45		C5		77		F0	77
123	Scrl		46		C5		7E		F0	7E

Table C-5 Scan Codes in overlay mode

Cap No.	Keytop		Code set 1				Code set 2			
			Make		Break		Make		Break	
08	7	(7)	47		C7		6C	F0	6C	
09	8	(8)	48		C8		75	F0	75	
10	9	(9)	49		C9		7D	F0	7D	
11	0	(*)	37		B7		7C	F0	7C	
23	U	(4)	4B		CB		6B	F0	6B	
24	I	(5)	4C		CC		73	F0	73	
25	O	(6)	4D		CD		74	F0	74	
26	P	(-)	4A		CA		7B	F0	7B	
37	J	(1)	4F		CF		69	F0	69	
38	K	(2)	50		D0		72	F0	72	
39	L	(3)	51		D1		7A	F0	7A	
40	;	(+)	4E		CE		79	F0	79	
52	M	(0)	52		D2		70	F0	70	
54	.	(.)	53		D3		71	F0	71	
55	/	(/)	E0 35		E0 B5		40 4A	E0 F0	4A	

Table C-6 No.124 key scan code

Key top	Shift	Code set 1				Code set 2			
		Make		Break		Make		Break	
Prt Sc	Common	E0 2A	E0 37	E0 B7	E0 AA	E0 12	E0 7C	E0 F0 7C	E0 F0 12
	Ctrl +	E0 37		E0 B7		E0 7C		E0 F0 7C	
	Shift +	E0 37		E0 B7		E0 7C		E0 F0 7C	
	Alt +		54	D4		84		F0 B4	



*Table C-7 No.126 key scan code*

Key top	Shift	Code set 1						Code set 2							
		Make						Make							
Pause	Common*	E1	1D	45	E1	9D	C5	E1	14	77	E1	F0	14	F0	77
	Ctrl*	E0	46	E0	C6			E0	7E	E0	F0	7E			

\*: This key generates only make codes.

## Appendix D Key Layout

### D.1 United States (US) Keyboard

Win7



Win8



Figure D-1 US keyboard

## D.2 Taiwan (TW) Keyboard

Win7



Win8



Figure D-2 TW keyboard

### D.3 Thai (TH) Keyboard

Win7



Win8



Figure D-3 TH keyboard

## D.4 Russian (RU) Keyboard

Win7



Win8



Figure D-4 RU keyboard



## D.5 Hebrew (HE) Keyboard

Win7



Win8



Figure D-5 HE keyboard

## D.6 Korean (KR) Keyboard

Win7



Win8



Figure D-6 KR keyboard

## D.7 UK-English (UK) Keyboard

Win7



Win8



Figure D-7 UK keyboard



## D.8 DU, UE, US International (USE) Keyboard

Win7



Win8



Figure D-8 USE keyboard

## D.9 Swiss/Switzerland (SL) Keyboard

Win7



Win8



Figure D-9 SL keyboard

## D.10 Arabic (AR) Keyboard

Win7



Win8



Figure D-10 AR keyboard

## D.11 Czech (CZ) Keyboard

Win7



Win8



Figure D-11 CZ keyboard



## D.12 Portuguese (PT) Keyboard

Win7



Win8



Figure D-12 PT keyboard

### D.13 Slovakian (SK) Keyboard

Win7



Win8



Figure D-13 SK keyboard

### D.14 Italian (IT) Keyboard

Win7



Win8



Figure D-14 IT keyboard

## D.15 French (FR) Keyboard

Win7



Win8



Figure D-15 FR keyboard



## D.16 German (GR) Keyboard

Win7



Win8



Figure D-16 GR keyboard

### D.17 Greek (GK) Keyboard

Win7



Win8



Figure D-17 GK keyboard

## D.18 Hungary (HU) Keyboard

Win7



Win8



Figure D-18 HU keyboard

## D.19 Spanish (SP) Keyboard

Win7



Win8



Figure D-19 SP keyboard



## D.20 Turkey (TR) Keyboard

Win7



Win8



Figure D-20 TR keyboard

## D.21 Turkish F (TF) Keyboard

Win7



Win8



Figure D-21 TF keyboard

## D.22 Belgian (BE) Keyboard

Win7



Win8



Figure D-22 BE keyboard

## D.23 Yugoslavia (YU) Keyboard

Win7



Win8



Figure D-23 YU keyboard



## D.24 Scandinavian (N5) Keyboard

Win7



Win8



Figure D-24 N5 keyboard

## D.25 Canadian Bilingual (CB) Keyboard

Win7



Win8



Figure D-25 CB keyboard

## D.26 Bulgaria (BU) Keyboard

Win7



Win8



Figure D-26 BU keyboard

## D.27 Japan (JP) Keyboard

Win7



Win8



Figure D-27 JP keyboard



### D.28 Latin America (LA) Keyboard

Win7



Win8



Figure D-28 LA keyboard

### D.29 Canadian Multilingual (CM) Keyboard

Win7



Win8



Figure D-29 CM keyboard

### D.30 Brazilian (BR) Keyboard

Win7



Win8



Figure D-30 BR keyboard